

**CITY OF BUNKER HILL VILLAGE  
PLANNING AND ZONING COMMISSION  
Agenda Request**

---

**Agenda Date:** July 26, 2022

**Agenda Item No:** IV

**Subject/Proceeding:** PUBLIC HEARING

**CONSIDERATION AND POSSIBLE ACTION ON A WRITTEN RECOMMENDATION TO THE CITY COUNCIL ON AN AMENDMENT TO THE SPECIFIC USE PERMIT FOR FROSTWOOD ELEMENTARY SCHOOL LOCATED AT 12214 MEMORIAL DRIVE TO ADD LIGHTING TO THE EXISTING ATHLETIC FIELDS**

**Exhibits:** Specific Use Permit Application, Site Plan, and Details  
Draft Ordinance for the Specific Use Permit Amendment  
Ordinance No. 12-413 Original Specific Use Permit for Frostwood Elementary School

**Clearance:** Steve Smith, Director of Public Works/Building Official  
Karen Glynn, City Administrator

### **Executive Summary**

A Specific Use Permit for Frostwood Elementary School, a public school located at 12214 Memorial Drive, was approved by the City Council (*as recommended by the Planning and Zoning Commission*) on April 17, 2012 as Ordinance No. 12 - 413.

Spring Branch Independent School District submitted an application to amend the Specific Use Permit to add lighting to the existing athletic fields located on the northeastern area of the property. The request requires an amendment to the existing Specific Use Permit to amend the site plan.

#### ***SUP/Amendment Process***

The purpose of the SUP process and regulations is to allow the proper integration of uses which may be suitable in specific locations within the City. Any future requests by the applicant must meet the existing Specific Use Permit or an amendment is required.

All Specific Use Permits and Amendments must be processed through the Planning and Zoning Commission that makes a recommendation to the City Council for approval or denial. The recommendation includes, but need not be limited to, the impact of the use and/or amendment on items such as:

- *Ingress and egress:* Ingress and egress to the property and proposed structures thereon, with particular reference to automobile and pedestrian safety and convenience, traffic flow and control, and access in the event of fire or other catastrophe.
- *Screening and buffering:* Screening and buffering, either or both, with reference to type, dimensions, and character.
- *Trees, yards and open spaces:* Landscaping and required yards, open spaces, and building setback lines.
- *Compatibility:* General compatibility with adjacent properties and other properties in the district and city.
- *Conformity:* The conformity of the proposed use with the requirements and intent of this ordinance and the comprehensive plan of the city.

The purpose of the SUP Process is to look at individual sites on a case-by-case basis and determine if the proposal would negatively impact adjacent properties and the City as a whole.

The SUP Process provides for conditions to be included to ensure specific concerns are addressed for the various factors.

***Amendment Application:***

As indicated on the submitted Specific Use Permit Application, S.B.I.S.D. has requested an amendment to the existing S.U.P. for Frostwood Elementary School to add lighting for the existing athletic fields.

Staff has reviewed the City's adopted ordinances for exterior lighting allowed in the City.

The ordinances are listed below:

***Sec. 4-201. Not to disturb others.***

It shall be unlawful for any person to cause or permit to be energized on property under his possession or control any outdoor lighting including, but not limited to, spotlights, floodlights or similar illuminating devices which project a glare or brightness, directly or indirectly, upon any lot, tract, or parcel of land, other than that upon which such outdoor lighting is situated, which shall annoy, disturb, injure or endanger the comfort, repose, health, peace or safety of others, within the limits of the city.

(Ord. No. 14-444, § 8, 10-21-14)

***Sec. 4-202. Indirect illumination.***

All outdoor lighting in the city consisting of spotlights, floodlights, or similar illuminating devices shall be installed, hooded, regulated and maintained by the owner or person in control

thereof in such a manner that the direct beam of any such light shall be cast downward so that it will not glare upon any lot, tract, or parcel of land other than that upon which it is situated and so that it will not cause or permit any illumination from indirect lighting in excess of one-half ( $\frac{1}{2}$ ) footcandle in, on, or over the ground at or beyond the boundary of the lot, parcel, or tract.

(Ord. No. 14-444, § 8, 10-21-14)

***Sec. 4-203. Location at game courts.***

Notwithstanding any other provision of this article, it shall be unlawful for any person to construct or install any outdoor lighting designed or used for the illumination of a tennis court, paddle ball court or other type game court unless all of the area occupied by such court is at least twenty-five (25) feet from all boundary lines of the property upon which such court is situated.

(Ord. No. 14-444, § 8, 10-21-14)

***Sec. 4-205. Hours of operation at game courts.***

All outdoor lighting designed or used for the purpose of illuminating tennis courts, paddle ball courts, or other type game courts shall be extinguished not later than 10:00 p.m. and shall not be turned on again until after 8:00 a.m. of the following day.

(Ord. No. 14-444, § 8, 10-21-14)

Review of the submitted site plan and lighting specifications indicates the following:

- The proposed lighting will be more than 25 feet from any property line.
- All proposed lighting will be directed inward onto the athletic fields/school property.
- All proposed lighting will be hooded/shielded as the ordinance requires. Light shields should be configured so that no direct line of sight is possible from the nearest property lines and the actual L.E.D. bulbs.
- The photometric analysis indicates that ambient or spill over lighting from the proposed lighting will be  $\frac{1}{2}$  foot candle or less at the property line. Please note that the area east of the athletic fields are public street ROWs and are currently illuminated by streetlights which exceed  $\frac{1}{2}$  foot candle.
- The proposed lighting would be controlled by a programmable timer to allow conformance to the City's sports court illumination hours which include no illumination between 10:00 p.m. and 8:00 a.m.

The SUP Process provides for conditions to be included to ensure specific concerns are addressed for the various factors.

A draft ordinance has been provided for review, comment and possible consideration by the Planning and Zoning Commission.

### *Process*

The Specific Use Permit (SUP) requires a recommendation by the Planning and Zoning Commission and approval by City Council.

The Planning and Zoning Commission held a workshop in June 2022 where Staff and the Frostwood Dad's Club presented the amendment.

As part of the process, this public hearing has been set before the Planning and Zoning Commission. Notifications to adjacent properties in Bunker Hill Village within 200 feet of the property were provided. The notice of the public hearing was provided in the City's newspaper of record and on the City's website.

Representatives from the Frostwood Dad's Club will be presenting their application to the Planning and Zoning Commission. Staff will outline the Ordinance. A public hearing will be held. The Commission will have the opportunity to review, discuss and take action.

### *Conclusion*

The purpose of this meeting is to hold a public hearing with consideration and possible action on a recommendation of an Ordinance for an amendment to the Specific Use Permit for Frostwood Elementary School to add lighting to the athletic fields.



CITY OF BUNKER HILL VILLAGE  
APPLICATION FOR  
SPECIFIC USE PERMIT

Entity Making Application Spring Branch Independent School District

Representative's Name: Travis T. Stanford, Associate Superintendent of Operations

Mailing Address: 1066 Gessner Dr., Houston, TX Zip: 77055

Property Address (If Different): 12214 Memorial Dr, Houston, TX 77024

Phone: 713-251-1008 Email: travis.stanford@springbranchisd.com

Category of Project (See 8.02 Below) Educational Facility Zoning District  $\Delta$  **B**

Description of Project Frostwood Elementary School will construct, install, and operate time-controlled, hooded field lights for the two athletic fields at the northeast section of the school grounds. The Project includes erecting two 60 foot gray steel light poles attached to two concrete footings and bases and recessed, hooded LED bulbs facing away from Plaintation and down onto the athletic fields.  
*(This description may be used for all meeting and public notices)*

Comments for Consideration of the Application: Recessed and hooded lights will prevent glare. The light will not exceed 0.5 lumens anywhere along the Frostwood Elementary School property line. The field lights will be connected to a stand-alone meter, may operate 7 days a week throughout the year, and will be controlled by an on/off switch and an automatic timer that will shut off the lights no later than 10:00 p.m. Following typical construction traffic and noise, the Project will simply extend into early evening hours permitted traffic, noise, and activities already associated with the athletic fields.

[Signature] [Signature] Date 05/20/2022

Attachments as applicable:  
• Site Plan  
• Any Additional Information  
*A fee of \$1,000.00 is required for processing*

Submitted by Putterman, Scharck & Assoc.



**Job Name:**  
FROSTWOOD ELEMENTARY

**Catalog Number:**  
PHOTMETRIC LAYOUT

Notes:

**Type:**

PSA21-145486

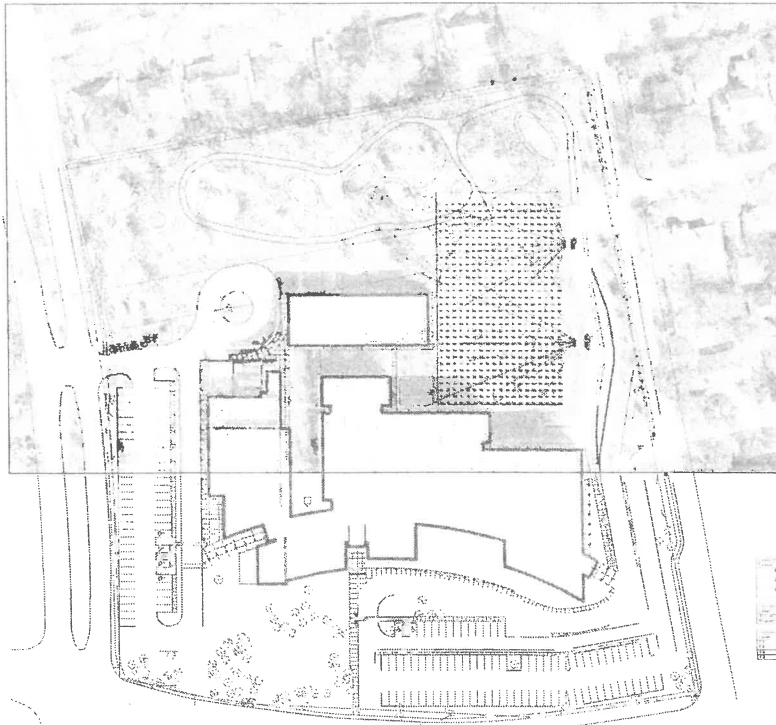

Lux/foot-candle data is obtained according to IES procedures under laboratory conditions. Field results may differ from computer model due to many factors, including ambient temperature, line voltage variations, lamp performance, installation, reflectances, and other site specific conditions.

Table with 4 columns and 10 rows of numerical data, likely representing light level measurements or simulation results. The columns are unlabeled but the values are organized in a structured grid.



**DRAWINGS FOR REVIEW ONLY  
DO NOT USE AS CONSTRUCTION DOCUMENTS**

Putterman, Scharck, & Associates, Inc.  
1000 University Ave.  
Hoboken, NJ 07030  
www.psaassociates.com

Revision table with columns for revision number and description. The first row shows 'XXX' in both columns. The second row shows '1' in the first column and 'Final' in the second column. The third row shows '1' in the first column and 'Final' in the second column. The fourth row shows '1' in the first column and 'Final' in the second column. The fifth row shows '1' in the first column and 'Final' in the second column.

Submitted by Putterman, Scharck & Assoc.



**Job Name:**  
FROSTWOOD ELEMENTARY

**Catalog Number:**  
EPH-LS-08-0640L-BLK-40-70-3S-  
C04-HV-AM-LY-A00-VHE-BP-ST  
Notes:

**Type:**  
**F3/F4/F5**

PSA21-145486

Project	Catalog #	Type
Prepared by	Notes	Date

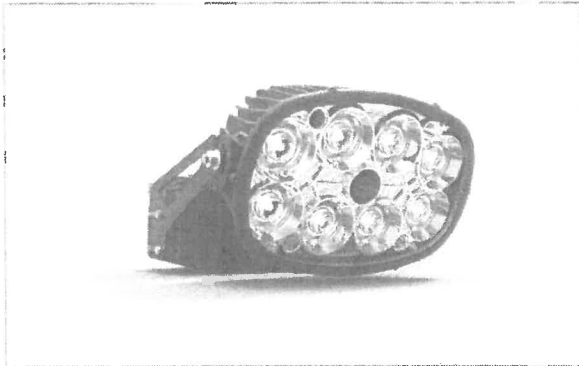

## Ephesus

### LUMASPORT 8

White LED Sports & Entertainment Luminaire

*Typical Applications*

Pro Arenas • University & Collegiate Arenas • University & Collegiate Stadiums • Multi-Event & Convention Centers • Gymnasiums & Field Houses

#### Interactive Menu

- Dimensional Details [page 1](#)
- Ordering Information [page 2](#)
- Dimensional and Mounting Details [page 3](#)
- Visor (VHE) Configuration [page 4](#)
- Performance Data [page 5](#)
- Optical Performance Data [page 6](#)
- Ordering Information for Accessories [page 8](#)
- Accessory Dimensions and Part Details [page 9](#)
- Example System Topology [page 12](#)

#### Product Certification



#### Top Product Features

- 55,000 or 90,000 lumen output options
- Glare and cutoff control via Hybrid Reflector and TIR Optical System
- Reduce install time with pre-aimable two-piece assembly
- Virtually eliminate maintenance with power redundancy
- Industry leading light source reliability with Chip-on-Board LEDs
- Greater than 92% lumen maintenance at 55,000 hours
- Wireless AirMesh, Wired DMX or sACN controls options to suit your needs

#### Dimensional Details

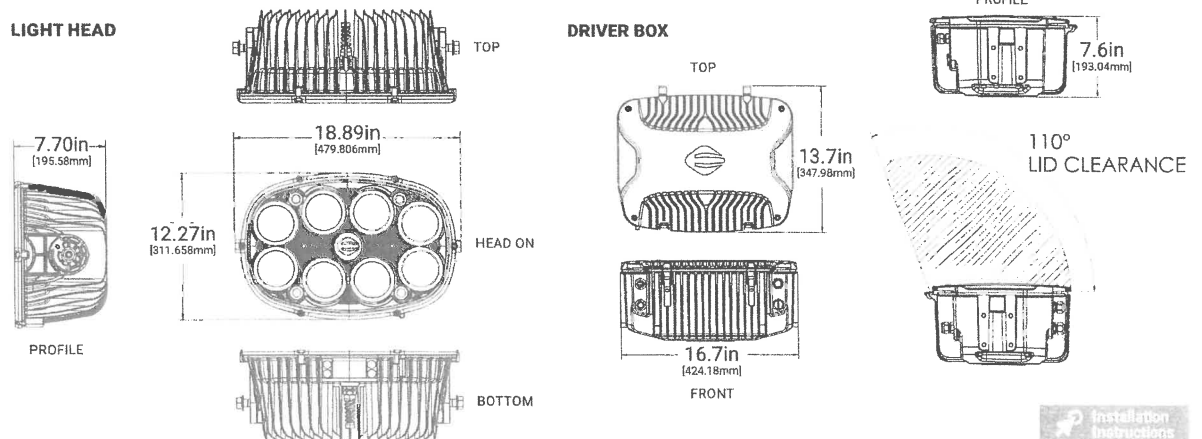

T0328018EN page 1  
"Ephesus" F3/F4/F5



**Job Name:**  
FROSTWOOD ELEMENTARY

**Catalog Number:**  
SLX60-D21-100-G-2GSS4 W/  
(2)CXA5180  
**Notes:**

**Type:**  
**POLE**

PSA21-145486

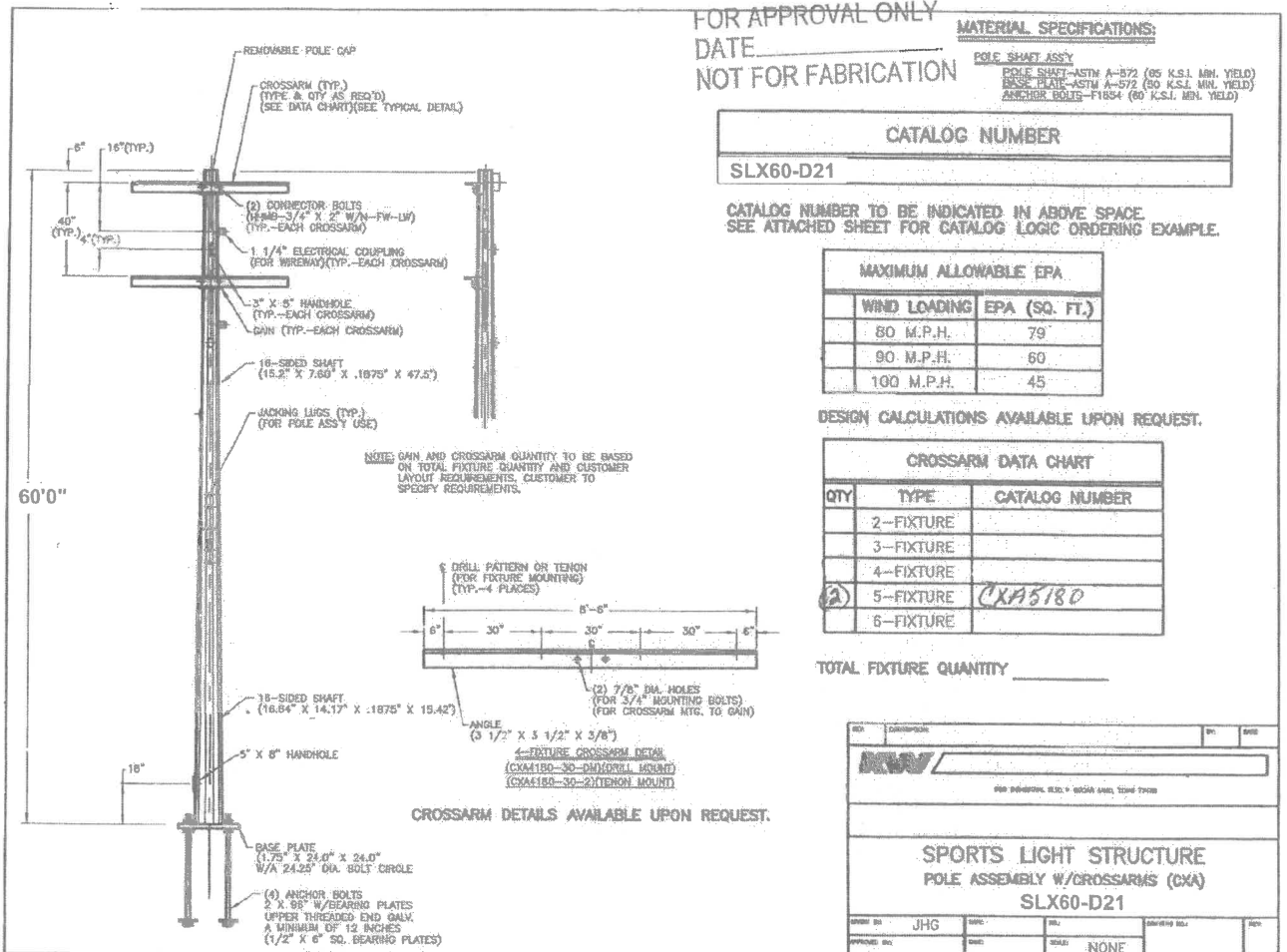



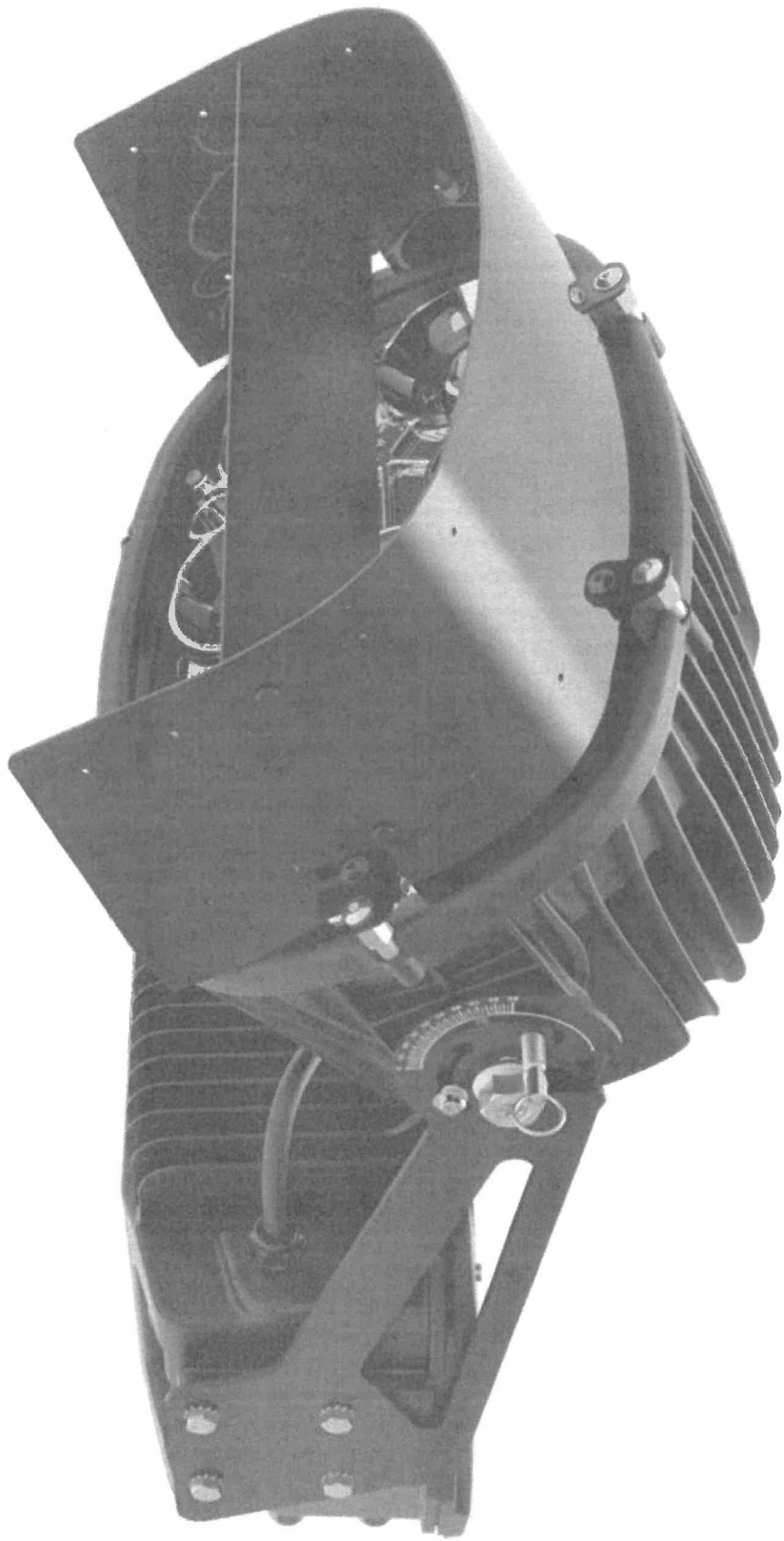

**ORDINANCE NO. 22-xxxxx**

**AN ORDINANCE OF THE CITY OF BUNKER HILL VILLAGE, TEXAS, AMENDING APPENDIX “A” OF THE CODE OF ORDINANCES OF THE CITY, SAME BEING THE COMPREHENSIVE ZONING ORDINANCE OF SAID CITY, BY GRANTING AN AMENDMENT TO THE SPECIFIC USE PERMIT TO THE SPRING BRANCH INDEPENDENT SCHOOL DISTRICT FOR THE CONSTRUCTION AND EDUCATIONAL USE FOR FROSTWOOD ELEMENTARY SCHOOL, 12214 MEMORIAL DRIVE TO ADD LIGHTING TO THE EXISTING ATHLETIC FIELDS; PROVIDING FOR REPEAL; PROVIDING A PENALTY OF AN AMOUNT NOT TO EXCEED \$2000 FOR EACH DAY OF VIOLATION OF ANY PROVISION HEREOF; AND PROVIDING FOR SEVERABILITY.**

\* \* \* \* \*

**WHEREAS**, Section 8.02 of Appendix “A: of the Code of Ordinances of the City of Bunker Hill Village, Texas, said Appendix “A” being the comprehensive zoning ordinance of said City, permits the use of educational facilities only pursuant to a specific use permit granted in accordance with Article VIII of said Appendix “A”; and

**WHEREAS**, The Spring Branch Independent School District was granted a specific use permit to construct and use the Frostwood Elementary School Facilities for Educational Purposes, by approval of the City Council as recommended by the Planning and Zoning Commission, to authorize the use of educational facilities on the premises at 12214 Memorial Drive located within said City in April 2012; and

**WHEREAS**, The Spring Branch Independent School District on behalf of Frostwood Elementary School has applied for an amendment to the specific use permit to authorize the installation of field lighting to light the existing athletic fields, in accordance with the plan attached hereto as Exhibits “A1 – A4” and made a part hereof for all purposes; and

**WHEREAS**, the Planning & Zoning Commission of said City, after notice and hearings as required by law, has recommended that the City Council grant the specific use permit; and

**WHEREAS**, the City Council, following notice and hearing as required by law, concurs with the recommendation of the Planning & Zoning Commission that such specific use permit should be granted; now, therefore

**BE IT ORDAINED BY THE CITY COUNCIL OF THE CITY OF BUNKER HILL VILLAGE, TEXAS:**

**Section 1.** An amendment to the specific use permit authorizing the installation of field lighting on the existing athletic fields to compliment the use of an educational facility, located on the premises of 12214 Memorial Drive, Bunker Hill Village, Texas, as shown on Exhibit “A1” Location Map, is hereby granted in accordance with the site plan attached hereto as Exhibits “A1 - A4” and in accordance with and subject to the special terms and conditions set forth in Section 2 of this Ordinance. Exhibits “A1 - A4” are made a part of this Ordinance for all purposes.

**Section 2.** The granting of the Amendment to the Specific Use Permit as set forth in Section 1 above is subject to the following additional terms and conditions:

- a. The installation will include two (2) sixty-foot (60’) gray steel light poles attached to two concrete footings and bases on the existing athletic fields as shown on Exhibit “A-2.” The design of the lights shall include recessed, hooded Light-emitting Diode (LED) bulbs facing away from Plantation and down onto the athletic fields as demonstrated on Exhibit “A-3” and “A-4.” No direct line of sight with the bulbs from adjacent properties shall result from the installation. The result of the lighting at the property line shall meet the City’s standard.
- b. The field lights will be connected to a stand-alone meter, may operate 7 days a week throughout the year, and will be controlled by an on/off switch and an automatic timer that will shut off the lights no later than 10:00 p.m.
- c. The site shall be maintained in accordance with these additional exhibits.
- d. All operations not regulated herein shall comply with all City ordinances.

**Section 3.** Repeal. All ordinances or parts of ordinances inconsistent or in conflict herewith are, to the extent of such inconsistency or conflict, hereby repealed.

**Section 4.** Penalty. Any person who shall violate any provision of this Ordinance shall be deemed guilty of a misdemeanor and, upon conviction, shall be fined in an amount not to exceed \$2000. Each day of violation shall constitute a separate offense.

**Section 5.** Severability. In the event any section, paragraph, subdivision, clause, phrase, provision, sentence, or part of this Ordinance or the application of the same to any person or circumstance shall for any reason be adjudged invalid or held unconstitutional by a court of competent jurisdiction, it shall not affect, impair, or invalidate this Ordinance as a whole or any part or provision hereof other than the part declared to be invalid or unconstitutional; and the City Council of the City of Bunker Hill Village, Texas, declares that it would have passed each and every part of the same notwithstanding the omission of any such part thus declared to be invalid or unconstitutional, or whether there be one or more parts.

**PASSED, APPROVED, AND ORDAINED** this xxx day of xxxx, 2022

---

Robert P. Lord, Mayor

ATTEST:

---

Karen H. Glynn, Acting City Secretary

Exhibits:

- A-1 Location Map
- A-2 Site Plan with Additional Field Lighting
- A-3 Site Plan with Lighting Vectors and Lumens
- A-4 Lighting Hood Design

**Specific Use Permit – Ordinance No. 22-xxx**  
**Spring Branch ISD for Frostwood Elementary School**  
12214 Memorial Drive  
Amendment to SUP – *Lighting for Athletic Fields*  
July 2022

*Exhibit A – 1*  
*Location Map*  
*12214 Memorial Drive*

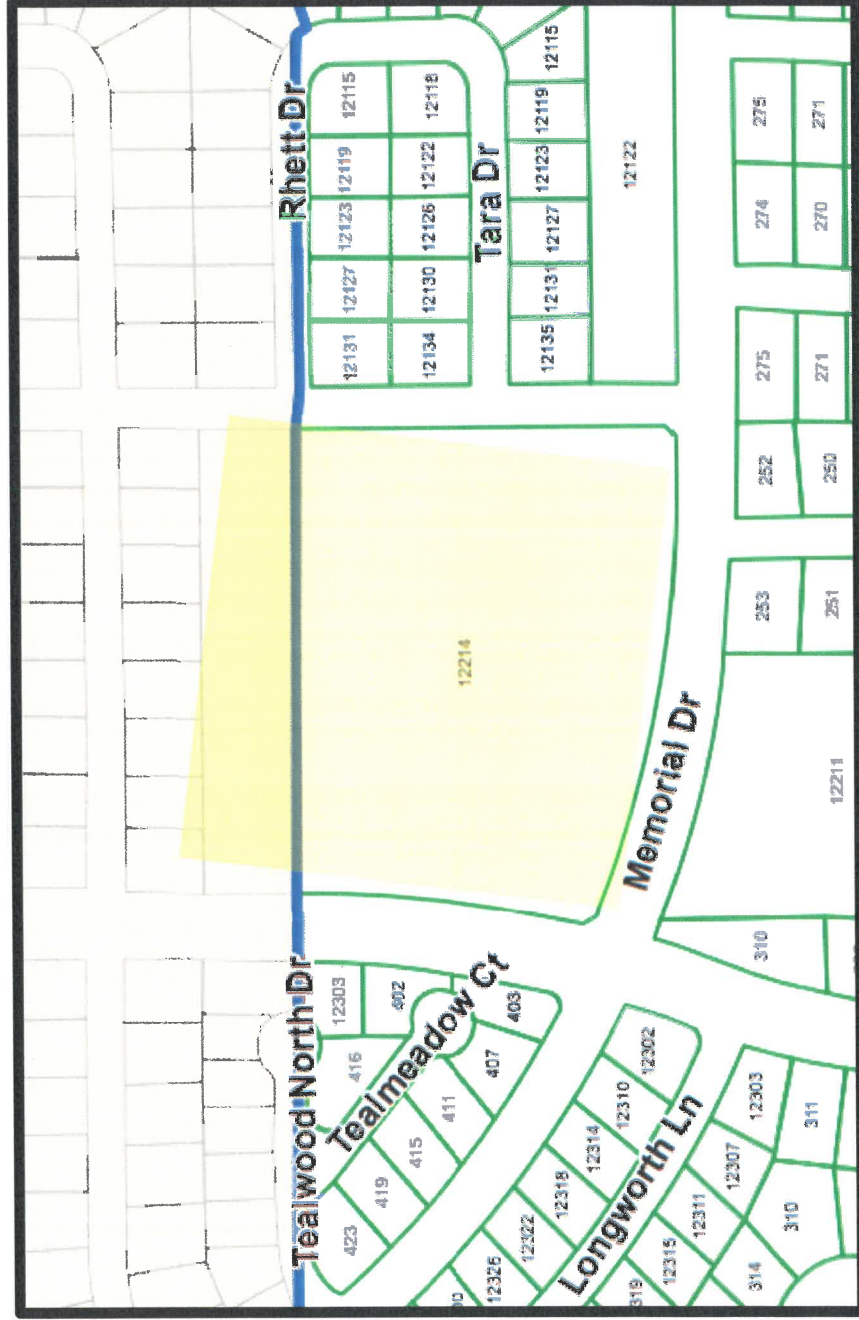

Specific Use Permit – Ordinance No. 22-xxx  
Spring Branch ISD for Frostwood Elementary School  
12214 Memorial Drive  
Amendment to SUP – Lighting for Athletic Fields  
July 2022

*Exhibit A – 2*  
*Site Plan with Additional Field Lighting*

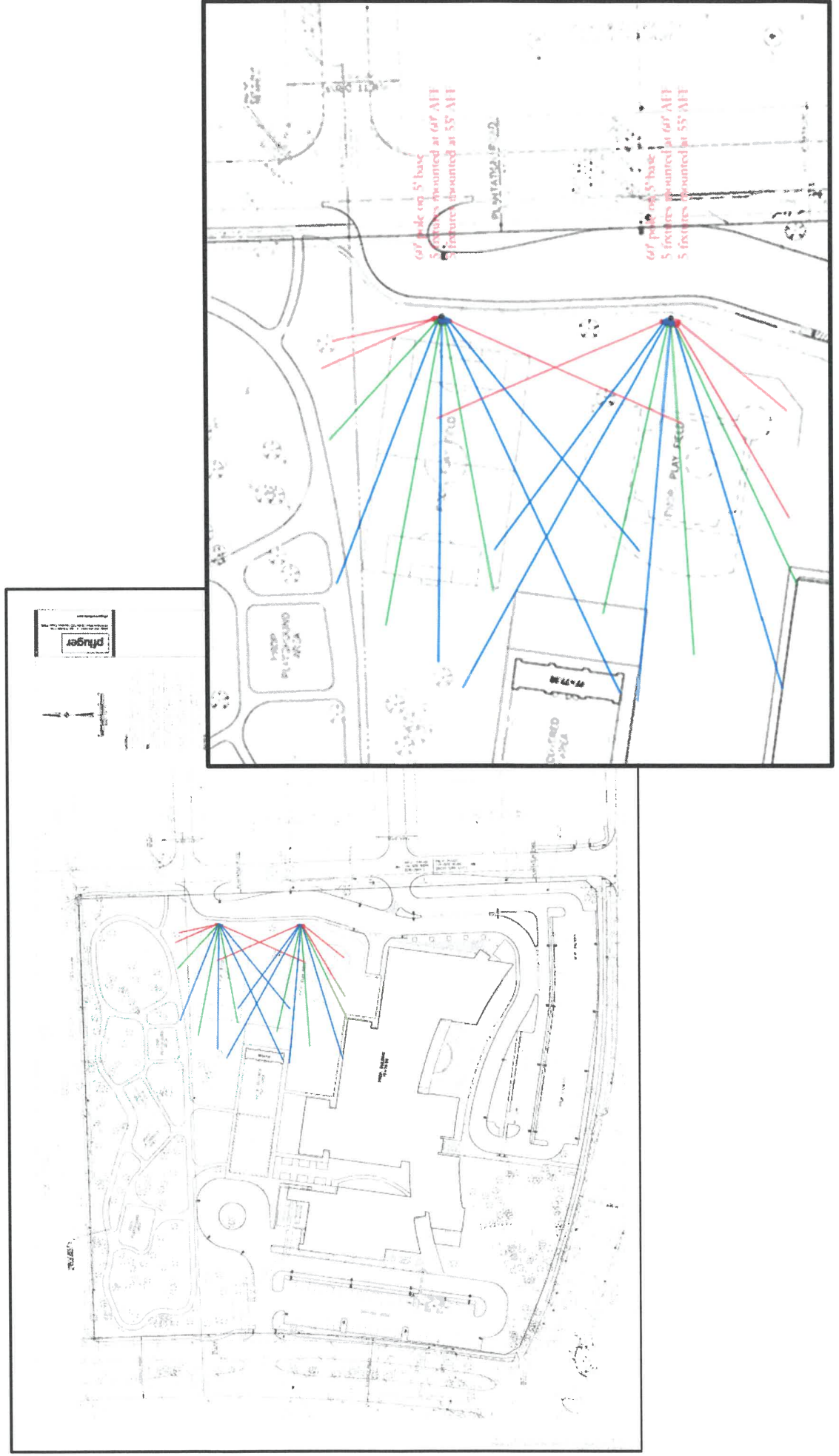

Specific Use Permit – Ordinance No. 22-xxx  
 Spring Branch ISD for Frostwood Elementary School  
 12214 Memorial Drive  
 Amendment to SUP – Lighting for Athletic Fields  
 July 2022

Exhibit A – 3  
 Site Plan with Lighting Vectors and Lumens

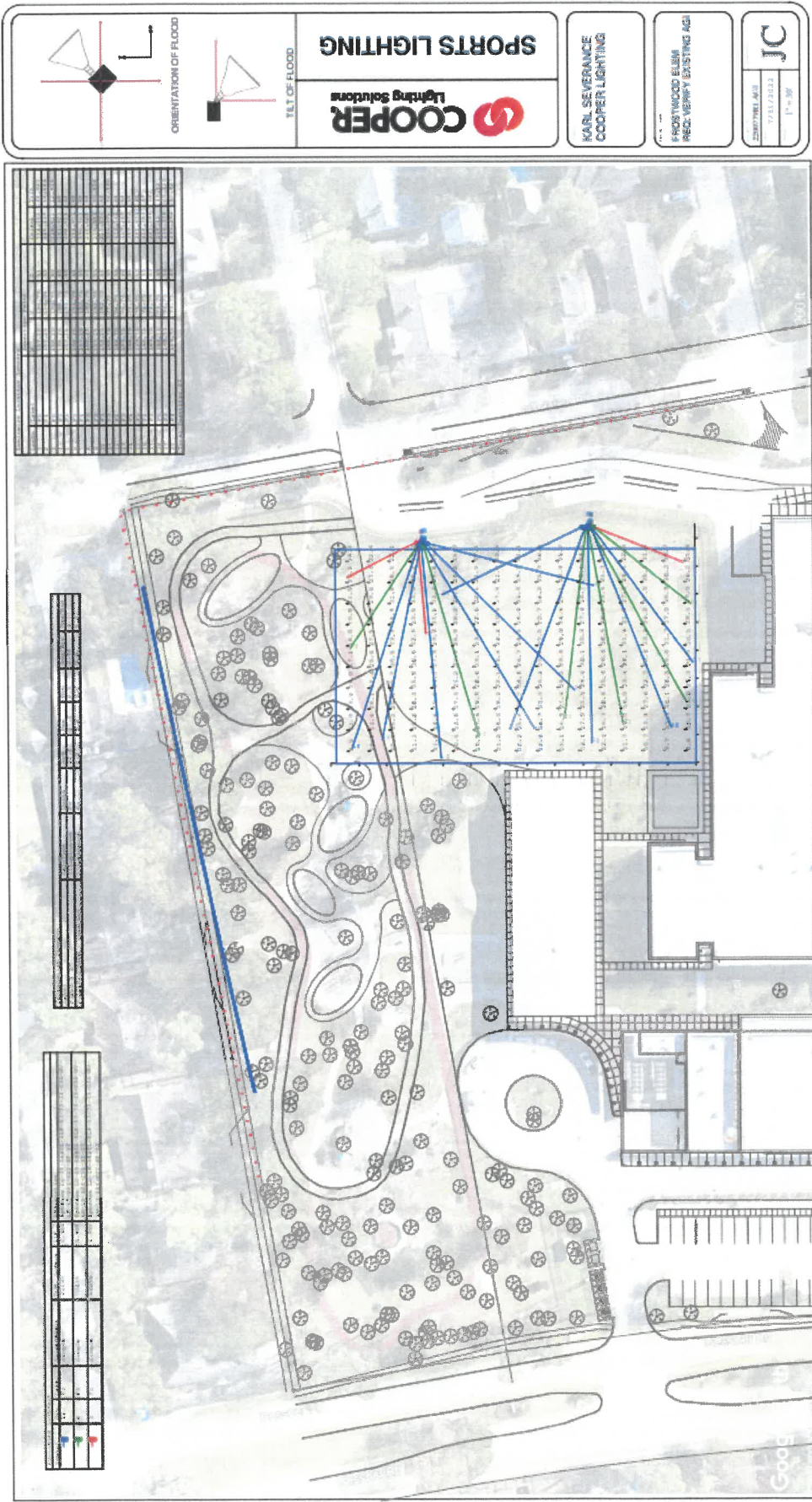

**Specific Use Permit – Ordinance No. 22-xxx**  
**Spring Branch ISD for Frostwood Elementary School**  
12214 Memorial Drive  
Amendment to SUP – *Lighting for Athletic Fields*  
July 2022

*Exhibit A – 4*

*Lighting Hood Design*

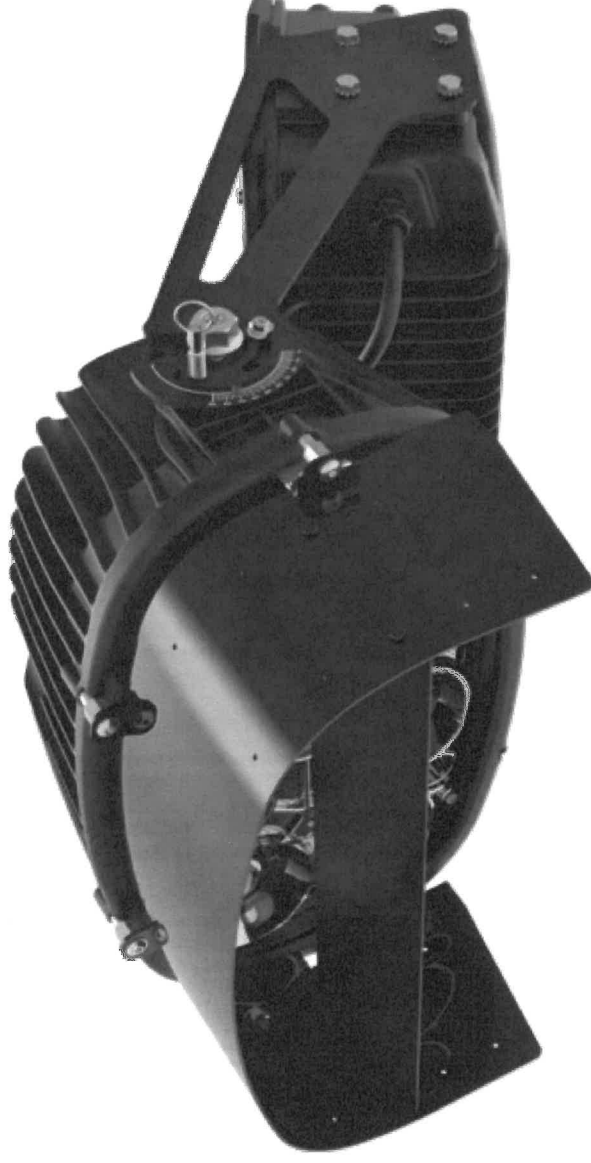



**ORDINANCE NO. 12-413**

**AN ORDINANCE OF THE CITY OF BUNKER HILL VILLAGE, TEXAS, AMENDING APPENDIX "A" OF THE CODE OF ORDINANCES OF THE CITY, SAME BEING THE COMPREHENSIVE ZONING ORDINANCE OF SAID CITY, BY GRANTING A SPECIFIC USE PERMIT TO THE SPRING BRANCH INDEPENDENT SCHOOL DISTRICT, AUTHORIZING CONSTRUCTION OF FROSTWOOD ELEMENTARY SCHOOL, 12214 MEMORIAL DRIVE; PROVIDING FOR REPEAL; PROVIDING A PENALTY OF AN AMOUNT NOT TO EXCEED \$2000 FOR EACH DAY OF VIOLATION OF ANY PROVISION HEREOF; AND PROVIDING FOR SEVERABILITY.**

WHEREAS, Section 8.02 of Appendix "A: of the Code of Ordinances of the City of Bunker Hill Village, Texas, said Appendix "A" being the comprehensive zoning ordinance of said City, permits the construction and use of educational facilities only pursuant to a specific use permit granted in accordance with Article VIII of said Appendix "A"; and

WHEREAS, The Spring Branch Independent School District has applied for a specific use permit for the construction and use of educational facilities on its premises located within said City, in accordance with the plan attached hereto as Exhibit "A" and made a part hereof; and

WHEREAS, the Planning & Zoning Commission of said City, after notice and hearings as required by law, has recommended that the City Council grant the specific use permit; and

WHEREAS, the City Council, following notice and hearing as required by law, concurs with the recommendation of the Planning & Zoning Commission that such specific use permit should be granted; now, therefore

**BE IT ORDAINED BY THE CITY COUNCIL OF THE CITY OF BUNKER HILL VILLAGE, TEXAS:**

**Section 1.** A specific use permit authorizing construction and use of an educational facility, to be located on the premises of the Spring Branch Independent School District, 12214 Memorial Drive, Bunker Hill Village, Texas, is hereby granted in accordance with the plans attached hereto as Exhibit "A" and in accordance with and

subject to the special terms and conditions set forth in Section 2 of this Ordinance. Said Exhibit "A" is made a part of this Ordinance for all purposes.

**Section 2.** The granting of the Specific Use Permit as set forth in Section 1 above is subject to the following additional terms and conditions:

- a. The sign lighting grid being a monochromatic, subdued color, such as amber or other color approved by the city engineer, and to be turned on only from dawn to dusk.

**Section 3.** Repeal. All ordinances or parts of ordinances inconsistent or in conflict herewith are, to the extent of such inconsistency or conflict, hereby repealed.

**Section 4.** Penalty. Any person who shall violate any provision of this Ordinance shall be deemed guilty of a misdemeanor and, upon conviction, shall be fined in an amount not to exceed \$2000. Each day of violation shall constitute a separate offense.

**Section 5.** Severability. In the event any section, paragraph, subdivision, clause, phrase, provision, sentence, or part of this Ordinance or the application of the same to any person or circumstance shall for any reason be adjudged invalid or held unconstitutional by a court of competent jurisdiction, it shall not affect, impair, or invalidate this Ordinance as a whole or any part or provision hereof other than the part declared to be invalid or unconstitutional; and the City Council of the City of Bunker Hill Village, Texas, declares that it would have passed each and every part of the same notwithstanding the omission of any such part thus declared to be invalid or unconstitutional, or whether there be one or more parts.

**PASSED, APPROVED, AND ADOPTED** this 17<sup>th</sup> day of April, 2012.

  
\_\_\_\_\_  
DERRY D. ESSARY, Mayor

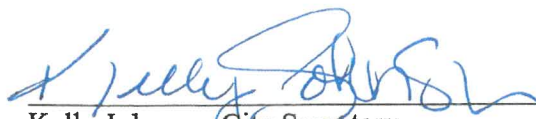
  
\_\_\_\_\_  
Kelly Johnson, City Secretary

# Frostwood Elementary School

## Spring Branch Independent School District

12214 Memorial Dr.  
Houston, TX 77024

# CONSTRUCTION DOCUMENTS

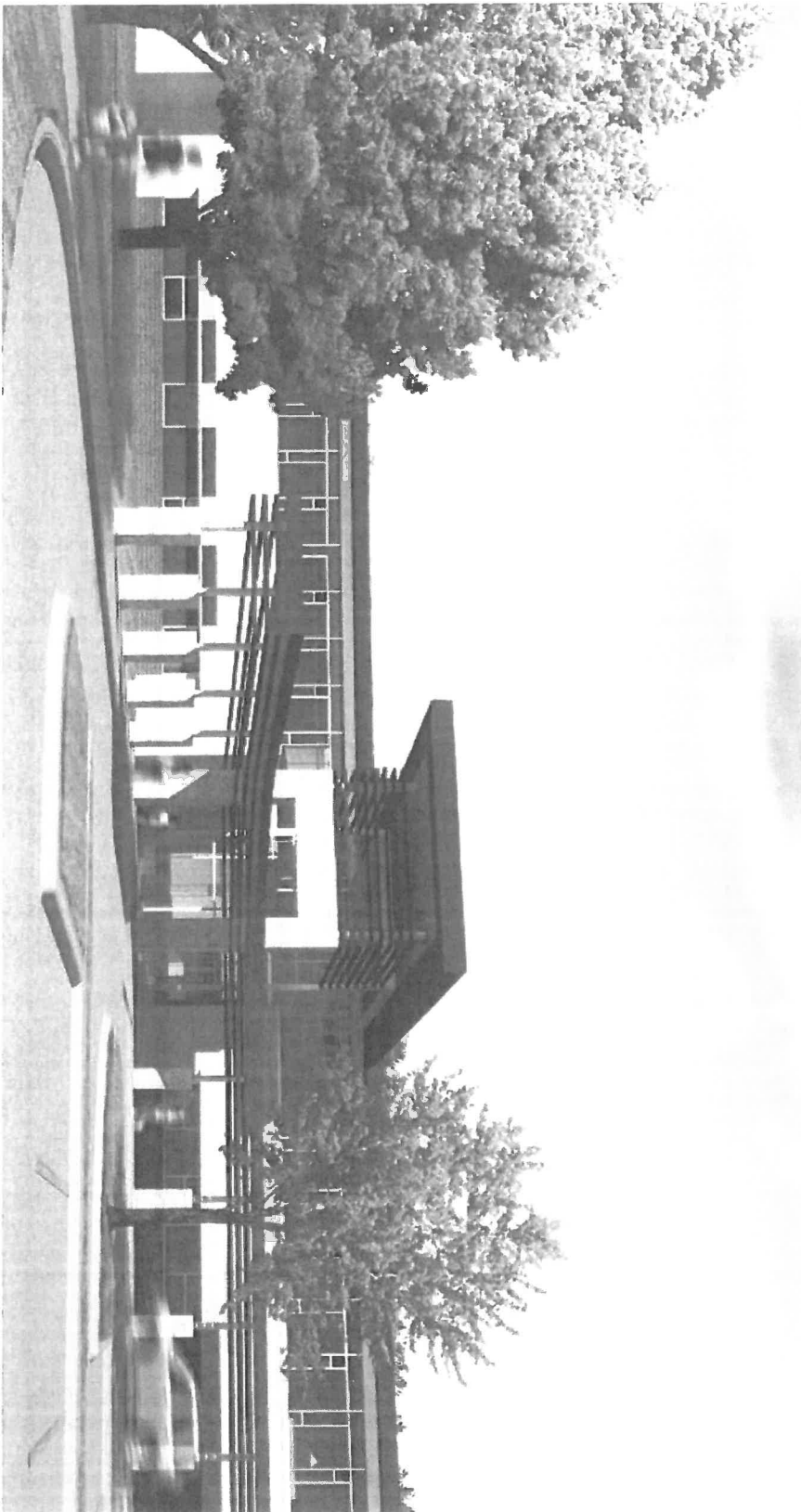

#### ARCHITECT

Pfluger Associates Architects  
4916 Main St. Ste. 100  
Houston, TX 77002  
PH: 713.222.1141  
FAX: 713.222.1174  
www.pflugerassociates.com

#### CIVIL ENGINEER

Bono & Sparo  
21627 Per Row Dr.  
Aly, TX 77449  
PH: 281.578.8995  
FAX: 281.578.8968  
www.bnos.com

#### STRUCTURAL ENGINEER

CJC Engineers  
3200 Brent Dr. e. Suite 775  
Houston, TX 77042  
Phone: 713.760.3345  
Fa: 713.760.3712  
www.cjce.com

#### MEP ENGINEER

DBR Engineers  
9744 Richmond A. e. Ste. 200  
Houston, TX 77042  
PH: 713.914.0888  
FAX: 713.914.0888  
www.dbrinc.com

#### LANDSCAPE ARCHITECT

Asa um Robinson  
1802 Ashington A. e. Suite A  
Houston, TX 77057  
PH: 713.537.2290  
FAX: 832.671.7188  
www.asa-um.com

#### FOOD SERVICE

Food Design Professionals  
28215 Oak Ridge Dr e  
The Woodlands, TX 77379  
PH: 281.357.2222  
FAX: 281.350.5555  
www.fooddesignpros.com

**pfluger**

12214 Memorial Dr. Houston, TX 77024  
4100 Main St. Ste. 100 Houston, TX 77002  
pfluger@pflugs.com

Frostwood Elementary School  
Spring Branch Independent School District  
12214 Memorial Dr  
Houston, TX 77024  
CONSTRUCTION DOCUMENTS

Spring Branch Independent  
School District  
956 Campbell St.  
Houston, TX 77024  
PH: 713.644.1511



A0.0  
C0.0

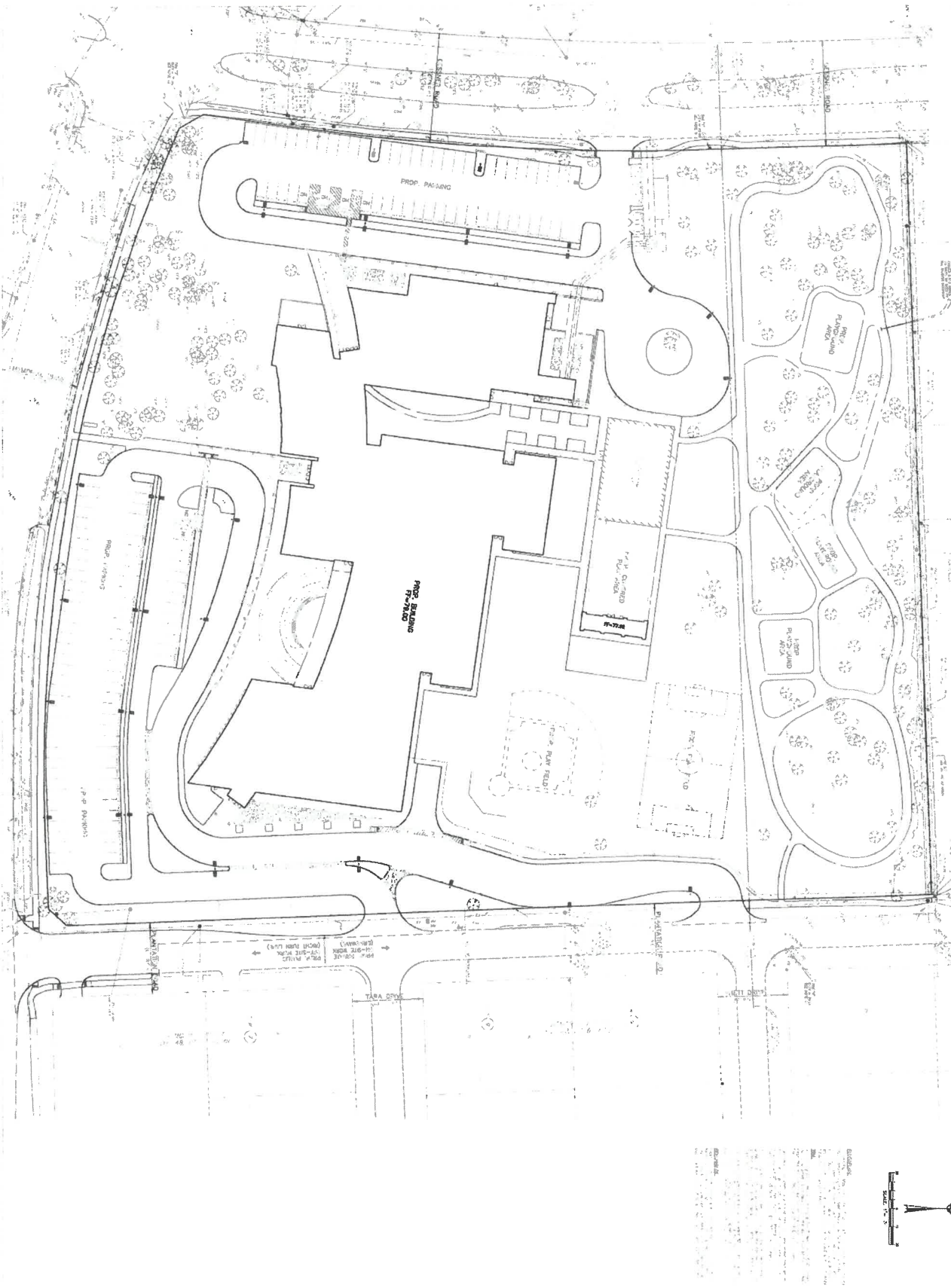

DATE: 11/11/11  
BY: [Signature]

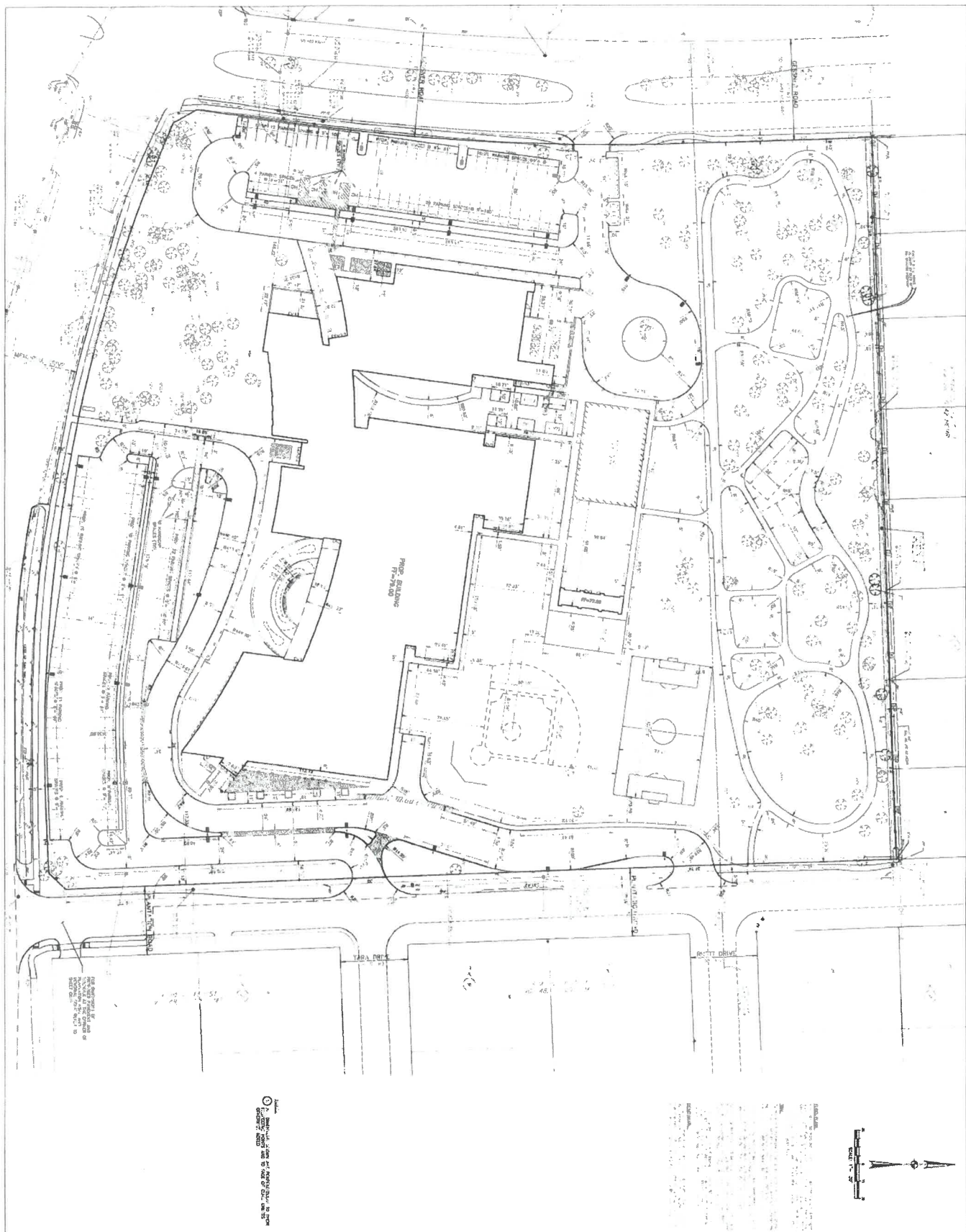

C104  
DIMENSIONAL  
LAYOUT



Spring Branch Independent  
School District  
955 Campbell St.  
Houston, TX 77024  
PH: 713.644.1511

**Frostwood Elementary School**  
Spring Branch Independent School District  
12214 Memorial Dr.  
Houston, TX 77024  
**CONSTRUCTION DOCUMENTS**

**pfluger**  
office: 713.973.1141 | fax: 713.973.1174  
 4913 Main Street, Suite 100, Houston, Texas 77002  
 pflugerarchitect.com



- 1. 1/2" = 1' - 0"
- 2. SEE SHEET C302 FOR OTHER DETAILS
- 3. SEE SHEET C303 FOR OTHER DETAILS
- 4. SEE SHEET C304 FOR OTHER DETAILS
- 5. SEE SHEET C305 FOR OTHER DETAILS
- 6. SEE SHEET C306 FOR OTHER DETAILS
- 7. SEE SHEET C307 FOR OTHER DETAILS
- 8. SEE SHEET C308 FOR OTHER DETAILS
- 9. SEE SHEET C309 FOR OTHER DETAILS
- 10. SEE SHEET C310 FOR OTHER DETAILS
- 11. SEE SHEET C311 FOR OTHER DETAILS
- 12. SEE SHEET C312 FOR OTHER DETAILS
- 13. SEE SHEET C313 FOR OTHER DETAILS
- 14. SEE SHEET C314 FOR OTHER DETAILS
- 15. SEE SHEET C315 FOR OTHER DETAILS
- 16. SEE SHEET C316 FOR OTHER DETAILS
- 17. SEE SHEET C317 FOR OTHER DETAILS
- 18. SEE SHEET C318 FOR OTHER DETAILS
- 19. SEE SHEET C319 FOR OTHER DETAILS
- 20. SEE SHEET C320 FOR OTHER DETAILS
- 21. SEE SHEET C321 FOR OTHER DETAILS
- 22. SEE SHEET C322 FOR OTHER DETAILS
- 23. SEE SHEET C323 FOR OTHER DETAILS
- 24. SEE SHEET C324 FOR OTHER DETAILS
- 25. SEE SHEET C325 FOR OTHER DETAILS
- 26. SEE SHEET C326 FOR OTHER DETAILS
- 27. SEE SHEET C327 FOR OTHER DETAILS
- 28. SEE SHEET C328 FOR OTHER DETAILS
- 29. SEE SHEET C329 FOR OTHER DETAILS
- 30. SEE SHEET C330 FOR OTHER DETAILS
- 31. SEE SHEET C331 FOR OTHER DETAILS
- 32. SEE SHEET C332 FOR OTHER DETAILS
- 33. SEE SHEET C333 FOR OTHER DETAILS
- 34. SEE SHEET C334 FOR OTHER DETAILS
- 35. SEE SHEET C335 FOR OTHER DETAILS
- 36. SEE SHEET C336 FOR OTHER DETAILS
- 37. SEE SHEET C337 FOR OTHER DETAILS
- 38. SEE SHEET C338 FOR OTHER DETAILS
- 39. SEE SHEET C339 FOR OTHER DETAILS
- 40. SEE SHEET C340 FOR OTHER DETAILS
- 41. SEE SHEET C341 FOR OTHER DETAILS
- 42. SEE SHEET C342 FOR OTHER DETAILS
- 43. SEE SHEET C343 FOR OTHER DETAILS
- 44. SEE SHEET C344 FOR OTHER DETAILS
- 45. SEE SHEET C345 FOR OTHER DETAILS
- 46. SEE SHEET C346 FOR OTHER DETAILS
- 47. SEE SHEET C347 FOR OTHER DETAILS
- 48. SEE SHEET C348 FOR OTHER DETAILS
- 49. SEE SHEET C349 FOR OTHER DETAILS
- 50. SEE SHEET C350 FOR OTHER DETAILS



<p><b>C301</b> STORM SE BR PLAN SHEET 1 OF 3</p>	 <p>Spring Branch Independent School District 955 Campbell St Houston, TX 77024 PH: 713.644.1511</p>	<p><b>Frostwood Elementary School</b> Spring Branch Independent School District 12214 Memorial Dr. Houston, TX 77024 <b>CONSTRUCTION DOCUMENTS</b></p>	 <p>Office: 713.222.1111   Fax: 713.222.1111 4115 Knox Memorial, Suite 100 Houston, Texas 77002 pfluger@pflugercbs.com</p>
--	---	--	---

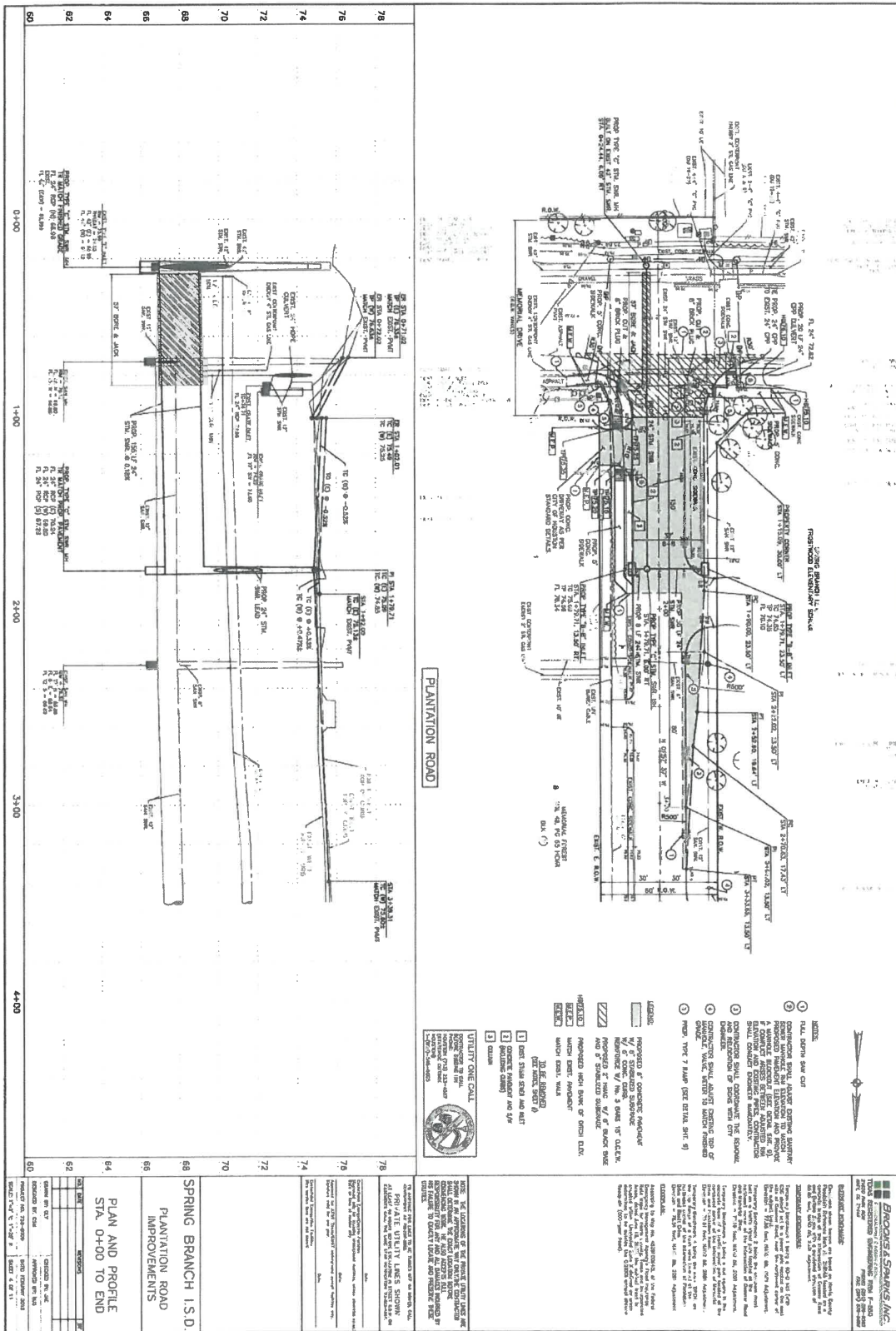

**6606**  
 PUBLIC  
 PLAN & PROFILE

Spring Branch Independent School District  
 955 Campbell St.  
 Houston, TX 77024  
 PH: 713.644.1511

Frostwood Elementary School  
 Spring Branch Independent School District  
 12214 Memorial Dr.  
 Houston, TX 77024

**CONSTRUCTION DOCUMENTS**

**pfluger**  
 12214 Memorial Dr., Houston, TX 77024  
 PH: 713.644.1511

07 Mar 2012 10:58AM B:\...  
F:\Projects\NSR\CA\Burger Arch\7350\7350\Public\REFERENCE\X-Tab-Public.dwg  
Includes Xref(s) { \$(CREFS) }

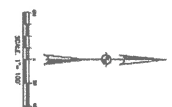
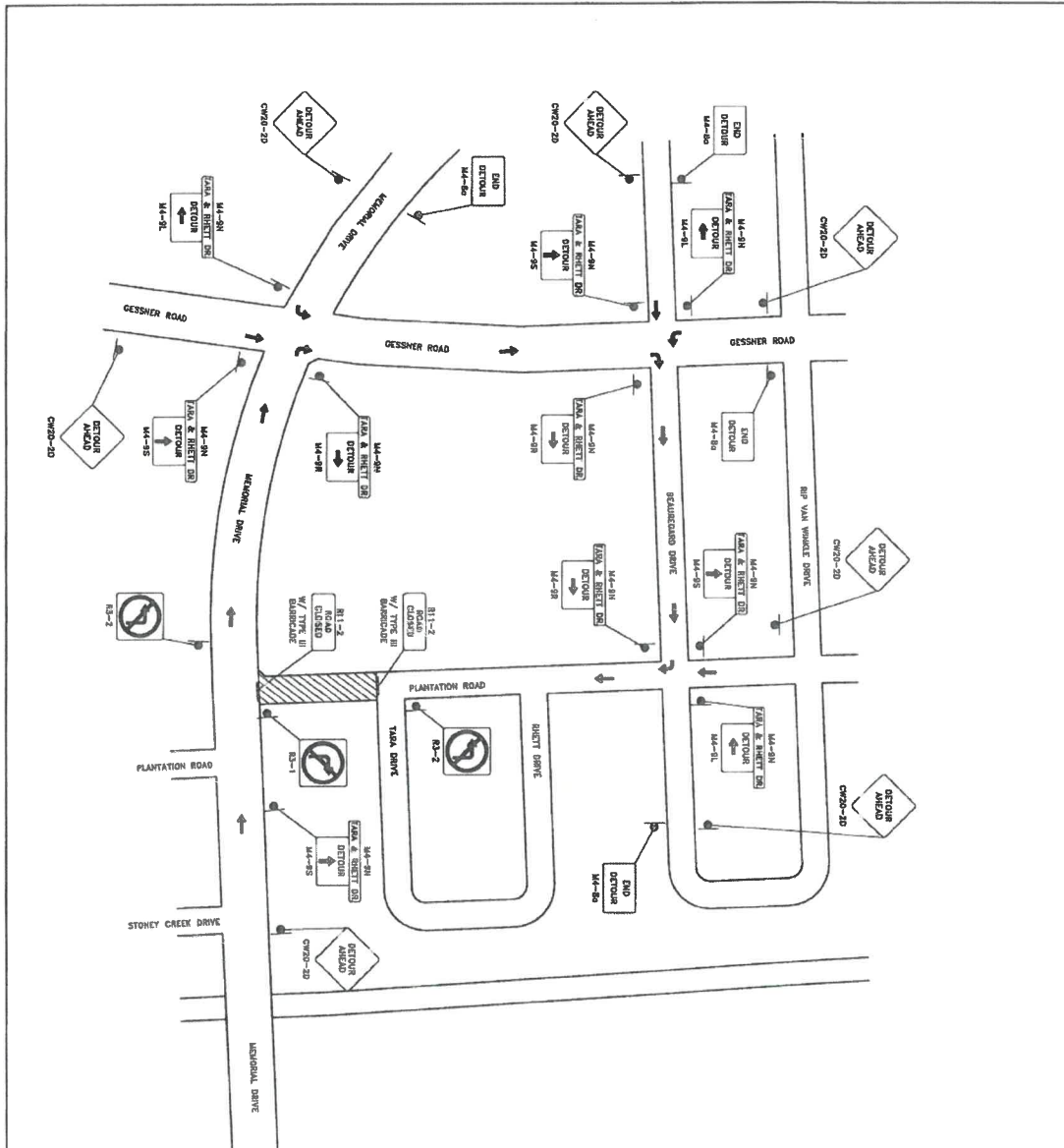

**LEGEND**

- TRAFFIC FLOW
- ⇄ PROP. SIGN
- CHANNELIZING DEVICE
- TYPE III BARRIERS
- FLASHER LOCATION

**NOTES**

1. CONTRACTOR SHALL... (M-4N, M-4S, M-4E, M-4W, R1-1, R1-2, R3-1, R3-2)
2. CONTRACTOR SHALL... (M-4N, M-4S, M-4E, M-4W, R1-1, R1-2, R3-1, R3-2)
3. CONTRACTOR SHALL... (M-4N, M-4S, M-4E, M-4W, R1-1, R1-2, R3-1, R3-2)
4. CONTRACTOR SHALL... (M-4N, M-4S, M-4E, M-4W, R1-1, R1-2, R3-1, R3-2)
5. CONTRACTOR SHALL... (M-4N, M-4S, M-4E, M-4W, R1-1, R1-2, R3-1, R3-2)

<b>PROJECT INFORMATION</b>	
PROJECT NO.	7350-0000
DATE	08/11/11
<b>DESIGN INFORMATION</b>	
DESIGNED BY	ARCHITECT
CHECKED BY	ARCHITECT
<b>APPROVALS</b>	
DATE	APPROVED
DATE	APPROVED
<b>CONTRACT INFORMATION</b>	
CONTRACT NO.	7350-0000
DATE	08/11/11

**SPRING BRANCH I.S.D.**  
PLANTATION ROAD IMPROVEMENTS  
TARA DRIVE AND RHETT DRIVE DETOUR PLAN

**Brooks & Sparks, Inc.**  
17214 Memorial Dr.  
Houston, TX 77024  
713.644.1511

**pfluger**  
ARCHITECTS

**C608**  
PUBLIC TARA DRIVE AND RHETT DRIVE DETOUR PLAN

**Frostwood Elementary School**  
Spring Branch Independent School District  
17214 Memorial Dr.  
Houston, TX 77024  
CONSTRUCTION DOCUMENTS

Spring Branch Independent School District  
955 Campbell St.  
Houston, TX 77024  
PH: 713.644.1511



17

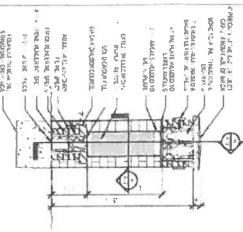

16

MARQUEE

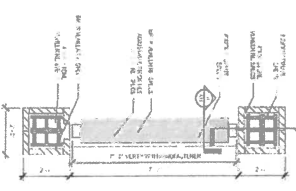

13

MARQUEE FLOOR PLAN

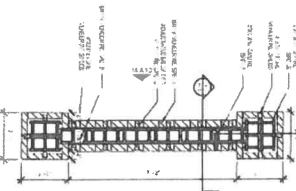

9

ENCLOSURE DETAIL

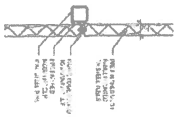

5

Reception Bin Plan

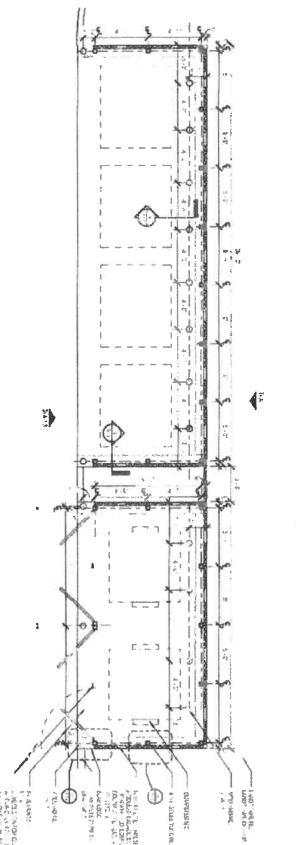

18

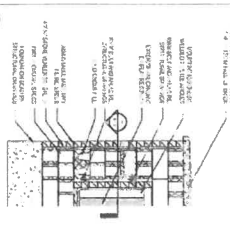

14

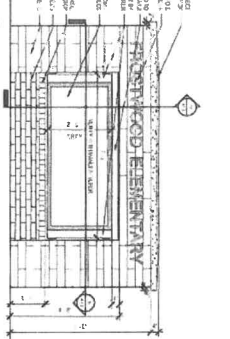

10

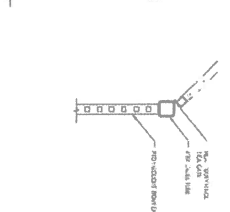

6

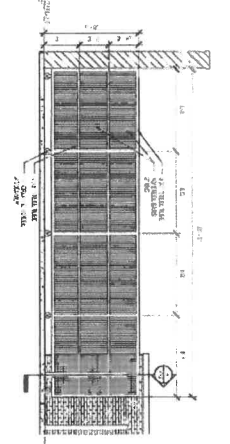

2

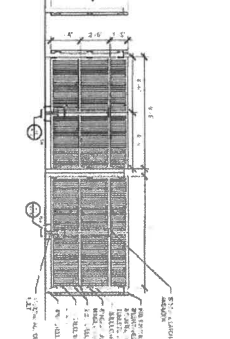

15

Expanded Screen Wall Plan

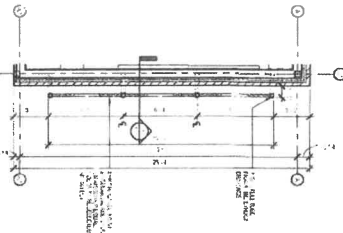

11

DUMPSTER ENCLOSURE GATE DETAIL

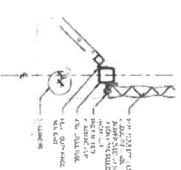

7

Dumpster Enclosure Elevation 2

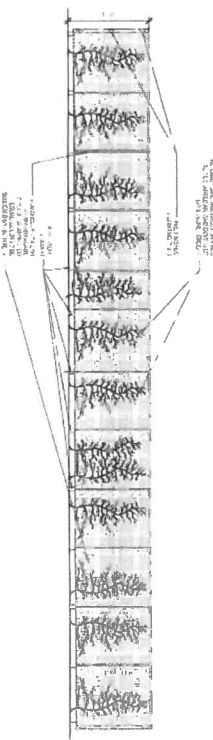

12

Roller Assem Bolt Detail

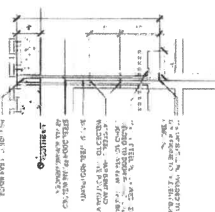

8

ROLLING GATE SECTION

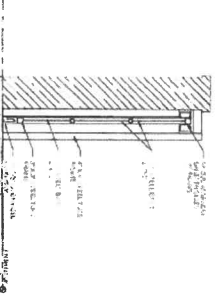

4

Dumpster Enclosure Section

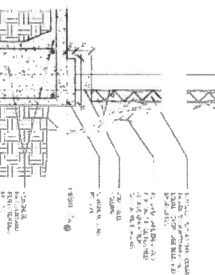

 Frostwood Elementary School  
 Spring Branch Independent School District  
 955 Campbell St.  
 Houston, TX 77024  
 PH: 713.644.1511

Frostwood Elementary School  
 Spring Branch Independent School District  
 12214 Memorial Dr.  
 Houston, TX 77044  
**CONSTRUCTION DOCUMENTS**

**pfluger**  
 4800 East Loop East, Suite 1415 • Houston, TX 77041  
 713.666.8200 • Fax: 713.666.8201 • www.pfluger.com  
 Pfluger Construction Documents

**A1.3**  
 Site Details