

**CITY OF BUNKER HILL VILLAGE**  
**CITY COUNCIL**  
**Agenda Request**

---

**Agenda Date:** August 16, 2022

**Agenda Item No:** IV

**Subject/Proceeding:** PUBLIC HEARING

**CONSIDERATION AND POSSIBLE ACTION ON ORDINANCE NO. 22-580 APPROVING AN AMENDMENT TO THE SPECIFIC USE PERMIT FOR FROSTWOOD ELEMENTARY SCHOOL LOCATED AT 12214 MEMORIAL DRIVE TO ADD LIGHTING TO THE EXISTING ATHLETIC FIELDS**

**Exhibits:** Proposed Ordinance No. 22-580 for the Specific Use Permit Amendment  
Specific Use Permit Application, Site Plan, and Details  
Ordinance No. 12-413 Original Specific Use Permit for Frostwood Elementary School

**Clearance:** Steve Smith, Director of Public Works/Building Official  
Karen Glynn, City Administrator

### **Executive Summary**

A Specific Use Permit for Frostwood Elementary School, a public school located at 12214 Memorial Drive, was approved by the City Council (*as recommended by the Planning and Zoning Commission*) on April 17, 2012 as Ordinance No. 12 - 413.

Spring Branch Independent School District submitted an application to amend the Specific Use Permit to add lighting to the existing athletic fields located on the northeastern area of the property. The request requires an amendment to the existing Specific Use Permit to amend the site plan.

#### ***SUP/Amendment Process***

The purpose of the SUP process and regulations is to allow the proper integration of uses which may be suitable in specific locations within the City. Any future requests by the applicant must meet the existing Specific Use Permit or an amendment is required.

All Specific Use Permits and Amendments must be processed through the Planning and Zoning Commission that makes a recommendation to the City Council for approval or denial. The recommendation includes, but need not be limited to, the impact of the use and/or amendment on items such as:

- *Ingress and egress:* Ingress and egress to the property and proposed structures thereon, with particular reference to automobile and pedestrian safety and convenience, traffic flow and control, and access in the event of fire or other catastrophe.
- *Screening and buffering:* Screening and buffering, either or both, with reference to type, dimensions, and character.
- *Trees, yards and open spaces:* Landscaping and required yards, open spaces, and building setback lines.
- *Compatibility:* General compatibility with adjacent properties and other properties in the district and city.
- *Conformity:* The conformity of the proposed use with the requirements and intent of this ordinance and the comprehensive plan of the city.

The purpose of the SUP Process is to look at individual sites on a case-by-case basis and determine if the proposal would negatively impact adjacent properties and the City as a whole.

The SUP Process provides for conditions to be included to ensure specific concerns are addressed for the various factors.

***Amendment Application:***

As indicated on the submitted Specific Use Permit Application, S.B.I.S.D. has requested an amendment to the existing S.U.P. for Frostwood Elementary School to add lighting for the existing athletic fields.

Staff has reviewed the City’s adopted ordinances for exterior lighting allowed in the City.

The ordinances are listed below:

***Sec. 4-201. Not to disturb others.***

It shall be unlawful for any person to cause or permit to be energized on property under his possession or control any outdoor lighting including, but not limited to, spotlights, floodlights or similar illuminating devices which project a glare or brightness, directly or indirectly, upon any lot, tract, or parcel of land, other than that upon which such outdoor lighting is situated, which shall annoy, disturb, injure or endanger the comfort, repose, health, peace or safety of others, within the limits of the city.

(Ord. No. 14-444, § 8, 10-21-14)

***Sec. 4-202. Indirect illumination.***

All outdoor lighting in the city consisting of spotlights, floodlights, or similar illuminating devices shall be installed, hooded, regulated and maintained by the owner or person in control thereof in such a manner that the direct beam of any such light shall be cast downward so that it will not glare upon any lot, tract, or parcel of land other than that upon which it is situated and so that it will not cause or permit any illumination from indirect lighting in excess of one-half (½) footcandle in, on, or over the ground at or beyond the boundary of the lot, parcel, or tract.

(Ord. No. 14-444, § 8, 10-21-14)

***Sec. 4-203. Location at game courts.***

Notwithstanding any other provision of this article, it shall be unlawful for any person to construct or install any outdoor lighting designed or used for the illumination of a tennis court, paddle ball court or other type game court unless all of the area occupied by such court is at least twenty-five (25) feet from all boundary lines of the property upon which such court is situated.

(Ord. No. 14-444, § 8, 10-21-14)

***Sec. 4-205. Hours of operation at game courts.***

All outdoor lighting designed or used for the purpose of illuminating tennis courts, paddle ball courts, or other type game courts shall be extinguished not later than 10:00 p.m. and shall not be turned on again until after 8:00 a.m. of the following day.

(Ord. No. 14-444, § 8, 10-21-14)

Review of the submitted site plan and lighting specifications indicates the following:

- The proposed lighting will be more than 25 feet from any property line.
- All proposed lighting will be directed inward onto the athletic fields/school property.
- All proposed lighting will be hooded/shielded as the ordinance requires. Light shields should be configured so that no direct line of site is possible from the nearest property lines and the actual L.E.D. bulbs.
- The photometric analysis indicates that ambient or spill over lighting from the proposed lighting will be ½ foot candle or less at the property line. Please note that the area east of the athletic fields are public street ROWs and are currently illuminated by streetlights which exceed ½ foot candle.
- The proposed lighting would be controlled by a programmable timer to allow conformance to the City's sports court illumination hours which include no illumination between 10:00 p.m. and 8:00 a.m.

The SUP Process provides for conditions to be included to ensure specific concerns are addressed for the various factors.

***Process***

The Specific Use Permit (SUP) requires a recommendation by the Planning and Zoning Commission and approval by City Council.

The Planning and Zoning Commission held a workshop in June 2022 where Staff and the Frostwood Dad's Club presented the amendment.

A public hearing was held before the Planning and Zoning Commission on July 26, 2022. Notifications to adjacent properties in Bunker Hill Village within 200 feet of the property were provided. The notice of the public hearing was provided in the City's newspaper of record and on the City's website. Representatives from the Frostwood Dad's Club also shared the notice with adjacent City of Houston Residents.

The Dad's Club and Staff presented the application and draft ordinance to the Planning and Zoning Commission. Several residents from the City of Houston who reside on Beauregard attended the hearing and made comments regarding parking and noise.

### ***Planning and Zoning Commission Recommendation***

On July 26, 2022, the Planning and Zoning Commission unanimously recommended that the City Council approve the proposed Ordinance for an amendment to the existing Specific Use Permit with the following key provisions as outlined in the ordinance:

- The design of the lights shall include recessed, hooded Light-emitting Diode (LED) bulbs facing away from Plantation and down onto the athletic fields. No direct line of sight with the bulbs from adjacent properties shall result from the installation. The result of the lighting at the property line shall meet the City's standard.
- The field lights will be connected to a stand-alone meter, may operate 7 days a week throughout the year, and will be controlled by an on/off switch and an automatic timer that will shut off the lights no later than 9:00 p.m. Use of the lights shall not begin any earlier than 8:00 a.m. When the fields are not in use, the lights shall be turned off.
- Use of the fields shall be limited to elementary school aged children and associated parents, coaches and guardians. The use of the fields while the lights are on shall be limited to practices and scrimmages. There shall be no amplified sound during practices and scrimmages. The field lighting may also be used for no more than three (3) movie nights per school year. The lights shall be turned off no later than 10:00 p.m. on each of these movie nights.
- There shall be no parking by those associated with the use of the athletic fields on Plantation Road, Rhett Drive, and Tara Drive. All parking by those associated with the use of the athletic fields shall be in the Frostwood Elementary School Parking Lots or the parking lots onsite at the Memorial Forest Club by permission.

### ***Conclusion***

The purpose of this meeting is to present the proposed Specific Use Permit Amendment and hold a Public Hearing. In addition, the Council has the opportunity for consideration and possible action on Ordinance No. 22-580 for approval of an Amendment to the Specific Use Permit for Frostwood Elementary School to add lighting to the existing athletic fields.

**ORDINANCE NO. 22-580**

**AN ORDINANCE OF THE CITY OF BUNKER HILL VILLAGE, TEXAS, AMENDING APPENDIX “A” OF THE CODE OF ORDINANCES OF THE CITY, SAME BEING THE COMPREHENSIVE ZONING ORDINANCE OF SAID CITY, BY GRANTING AN AMENDMENT TO THE SPECIFIC USE PERMIT TO THE SPRING BRANCH INDEPENDENT SCHOOL DISTRICT FOR THE CONSTRUCTION AND EDUCATIONAL USE FOR FROSTWOOD ELEMENTARY SCHOOL, 12214 MEMORIAL DRIVE TO ADD LIGHTING TO THE EXISTING ATHLETIC FIELDS; PROVIDING FOR REPEAL; PROVIDING A PENALTY OF AN AMOUNT NOT TO EXCEED \$2000 FOR EACH DAY OF VIOLATION OF ANY PROVISION HEREOF; AND PROVIDING FOR SEVERABILITY.**

\* \* \* \* \*

**WHEREAS**, Section 8.02 of Appendix “A: of the Code of Ordinances of the City of Bunker Hill Village, Texas, said Appendix “A” being the comprehensive zoning ordinance of said City, permits the use of educational facilities only pursuant to a specific use permit granted in accordance with Article VIII of said Appendix “A”; and

**WHEREAS**, The Spring Branch Independent School District was granted a specific use permit to construct and use the Frostwood Elementary School Facilities for Educational Purposes, by approval of the City Council as recommended by the Planning and Zoning Commission, to authorize the use of educational facilities on the premises at 12214 Memorial Drive located within said City in April 2012; and

**WHEREAS**, The Spring Branch Independent School District on behalf of Frostwood Elementary School has applied for an amendment to the specific use permit to authorize the installation of field lighting to light the existing athletic fields, in accordance with the plan attached hereto as Exhibits “A1 – A4” and made a part hereof for all purposes; and

**WHEREAS**, the Planning & Zoning Commission of said City, after notice and hearings as required by law, has recommended that the City Council grant the specific use permit; and

**WHEREAS**, the City Council, following notice and hearing as required by law, concurs with the recommendation of the Planning & Zoning Commission that such specific use permit should be granted; now, therefore

**BE IT ORDAINED BY THE CITY COUNCIL OF THE CITY OF BUNKER HILL VILLAGE, TEXAS:**

**Section 1.** An amendment to the specific use permit authorizing the installation of field lighting on the existing athletic fields to compliment the use of an educational facility, located on the premises of 12214 Memorial Drive, Bunker Hill Village, Texas, as shown on Exhibit “A1” Location Map, is hereby granted in accordance with the site plan attached hereto as Exhibits “A1 - A4” and in accordance with and subject to the special terms and conditions set forth in Section 2 of this Ordinance. Exhibits “A1 - A4” are made a part of this Ordinance for all purposes.

**Section 2.** The granting of the Amendment to the Specific Use Permit as set forth in Section 1 above is subject to the following additional terms and conditions:

- a. The installation will include two (2) sixty-foot (60’) gray steel light poles attached to two concrete footings and bases on the existing athletic fields as shown on Exhibit “A-2.” The design of the lights shall include recessed, hooded Light-emitting Diode (LED) bulbs facing away from Plantation and down onto the athletic fields as demonstrated on Exhibit “A-3” and “A-4.” No direct line of sight with the bulbs from adjacent properties shall result from the installation. The result of the lighting at the property line shall meet the City’s standard.
- b. The field lights will be connected to a stand-alone meter, may operate 7 days a week throughout the year, and will be controlled by an on/off switch and an automatic timer that will shut off the lights no later than 9:00 p.m. Use of the lights shall not begin any earlier than 8:00 a.m. When the fields are not in use, the lights shall be turned off.
- c. Use of the fields shall be limited to elementary school aged children and associated parents, coaches and guardians. The use of the fields while the lights are on shall be limited to practices and scrimmages. There shall be no amplified sound during practices and scrimmages. The field lighting may also be used for no more than three (3) movie nights per school year. The lights shall be turned off no later than 10:00 p.m. on each of these movie nights.
- d. There shall be no parking by those associated with the use of the athletic fields on Plantation Road, Rhett Drive, and Tara Drive. All parking by those associated with the use of the athletic fields shall be in the Frostwood

Elementary School Parking Lots or the parking lots onsite at the Memorial Forest Club by permission.

- e. The site shall be maintained in accordance with these additional exhibits.
- f. All operations not regulated herein shall comply with all City ordinances.

**Section 3.** Repeal. All ordinances or parts of ordinances inconsistent or in conflict herewith are, to the extent of such inconsistency or conflict, hereby repealed.

**Section 4.** Penalty. Any person who shall violate any provision of this Ordinance shall be deemed guilty of a misdemeanor and, upon conviction, shall be fined in an amount not to exceed \$2000. Each day of violation shall constitute a separate offense.

**Section 5.** Severability. In the event any section, paragraph, subdivision, clause, phrase, provision, sentence, or part of this Ordinance or the application of the same to any person or circumstance shall for any reason be adjudged invalid or held unconstitutional by a court of competent jurisdiction, it shall not affect, impair, or invalidate this Ordinance as a whole or any part or provision hereof other than the part declared to be invalid or unconstitutional; and the City Council of the City of Bunker Hill Village, Texas, declares that it would have passed each and every part of the same notwithstanding the omission of any such part thus declared to be invalid or unconstitutional, or whether there be one or more parts.

**PASSED, APPROVED, AND ORDAINED** this 16<sup>th</sup> day of August, 2022

---

Robert P. Lord, Mayor

ATTEST:

---

Karen H. Glynn, Acting City Secretary

Exhibits:

- A-1 Location Map
- A-2 Site Plan with Additional Field Lighting
- A-3 Site Plan with Lighting Vectors and Lumens
- A-4 Design and Hooding Details

**Specific Use Permit – Ordinance No. 22-580**  
**Spring Branch ISD for Frostwood Elementary School**  
12214 Memorial Drive  
Amendment to SUP – *Lighting for Athletic Fields*  
August 2022

*Exhibit A – 1*  
*Location Map*  
*12214 Memorial Drive*





**Specific Use Permit – Ordinance No. 22-580**  
**Spring Branch ISD for Frostwood Elementary School**  
12214 Memorial Drive  
Amendment to SUP – *Lighting for Athletic Fields*  
August 2022

*Exhibit A – 2*  
*Site Plan with Additional Field Lighting*

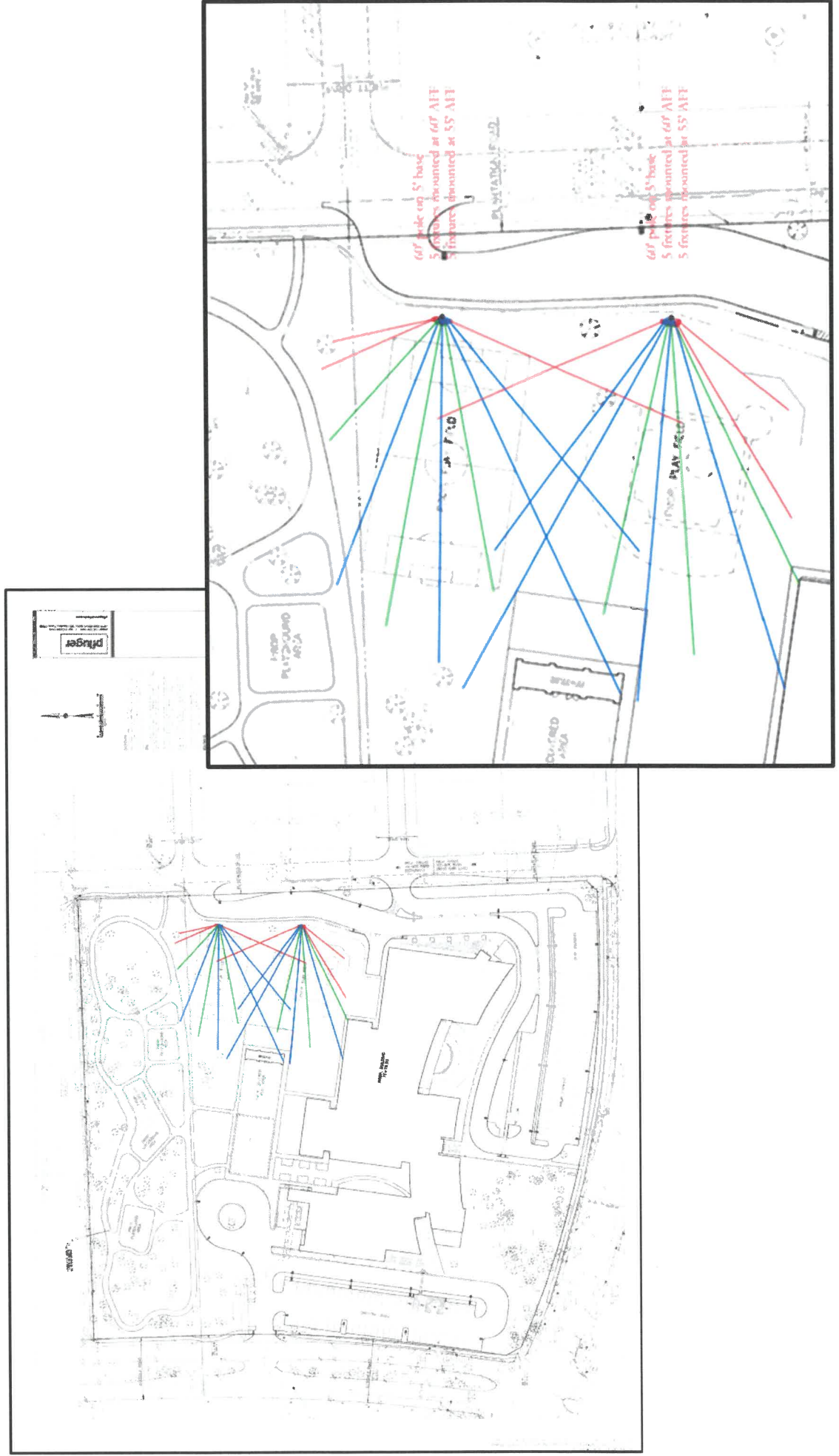

**Specific Use Permit – Ordinance No. 22-580**  
**Spring Branch ISD for Frostwood Elementary School**  
 12214 Memorial Drive  
 Amendment to SUP – Lighting for Athletic Fields  
 August 2022

*Exhibit A – 3*  
*Site Plan with Lighting Vectors and Lumens*

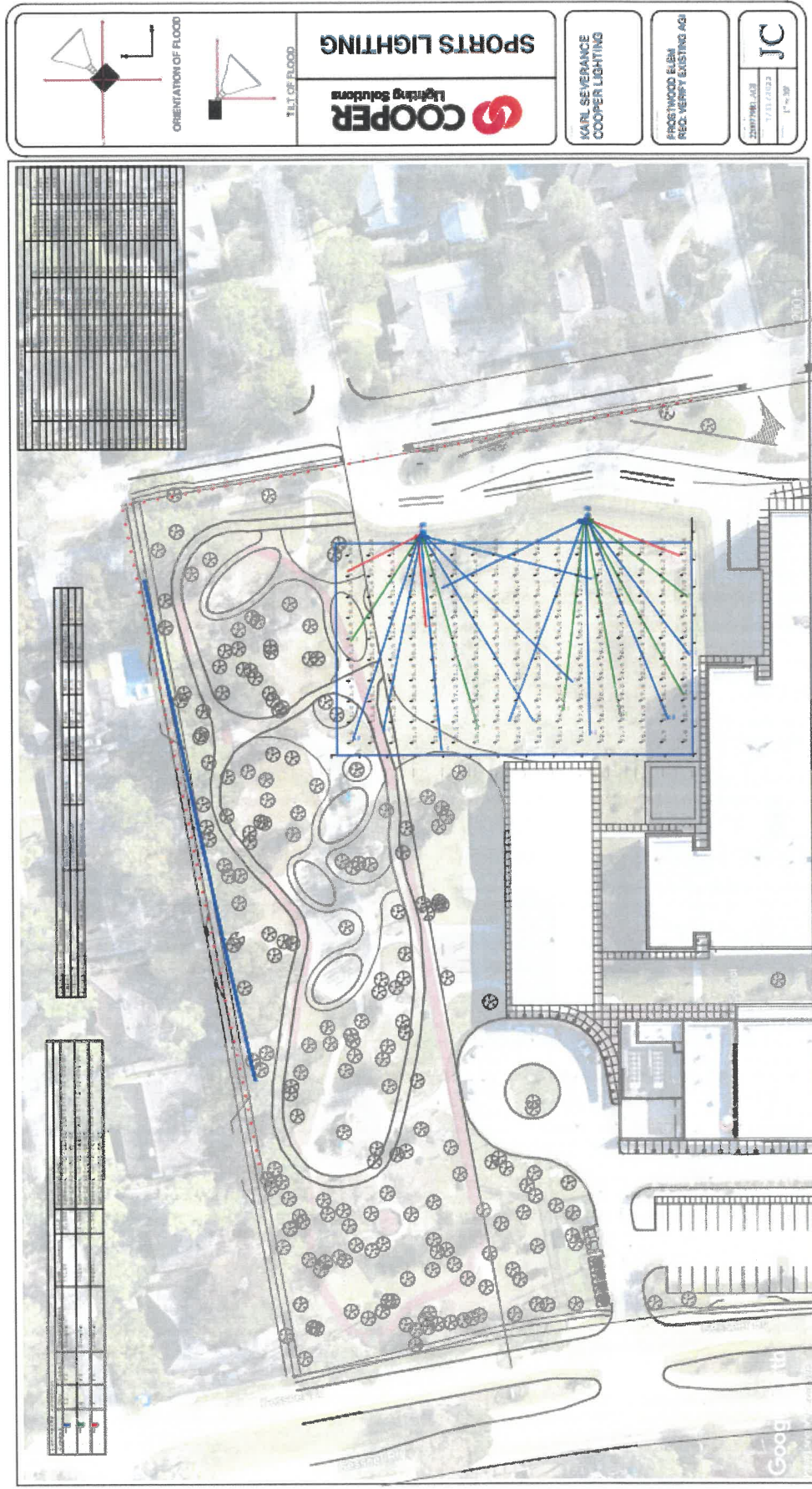

**Specific Use Permit – Ordinance No. 22-580**  
**Spring Branch ISD for Frostwood Elementary School**  
12214 Memorial Drive  
Amendment to SUP – *Lighting for Athletic Fields*  
August 2022

*Exhibit A – 4*

*Lighting Hood Design*

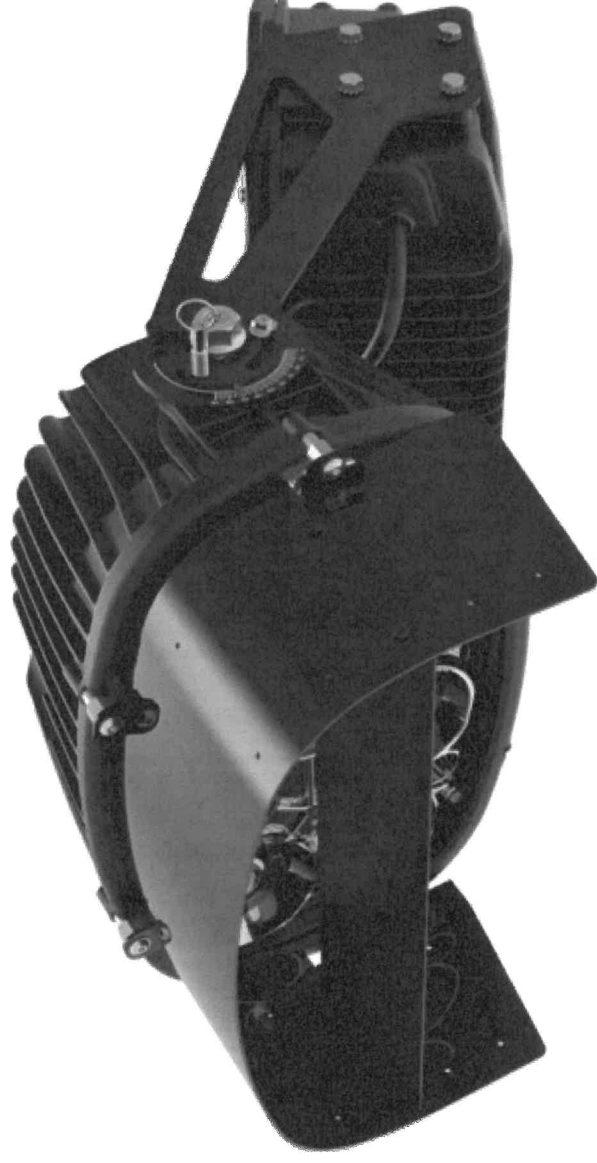





CITY OF BUNKER HILL VILLAGE  
APPLICATION FOR  
SPECIFIC USE PERMIT

Entity Making Application Spring Branch Independent School District

Representative's Name: Travis T. Stanford, Associate Superintendent of Operations

Mailing Address: 1066 Gessner Dr., Houston, TX Zip: 77055

Property Address (If Different): 12214 Memorial Dr, Houston, TX 77024

Phone: 713-251-1008 Email: travis.stanford@springbranchisd.com

Category of Project (See 8.02 Below) Educational Facility Zoning District A B

Description of Project Frostwood Elementary School will construct, install, and operate time-controlled, hooded field lights for the two athletic fields at the northeast section of the school grounds. The Project includes erecting two 60 foot gray steel light poles attached to two concrete footings and bases and recessed, hooded LED bulbs facing away from Plaintation and down onto the athletic fields.

*(This description may be used for all meeting and public notices)*

Comments for Consideration of the Application: Recessed and hooded lights will prevent glare.

The light will not exceed 0.5 lumens anywhere along the Frostwood Elementary School property

line. The field lights will be connected to a stand-alone meter, may operate 7 days a week throughout

the year, and will be controlled by an on/off switch and an automatic timer that will shut off the

lights no later than 10:00 p.m. Following typical construction traffic and noise, the Project will simply extend into early evening hours permitted traffic, noise, and activities already associated with the athletic fields.

Travis T. Stanford  
Signature of Applicant

05/20/2022  
Date

Attachments as applicable:

- Site Plan
- Any Additional Information

*A fee of \$1,000.00 is required for processing*

Submitted by Putterman, Scharck & Assoc.



**Job Name:**  
FROSTWOOD ELEMENTARY

**Catalog Number:**  
PHOTMETRIC LAYOUT

**Type:**

Notes:

PSA21-145486

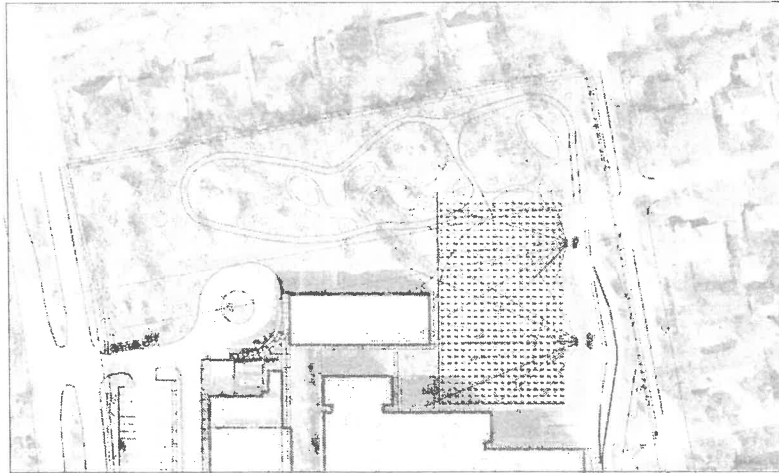

Room	Area	Height	Lighting	Notes
101	1000	10	40	
102	1000	10	40	
103	1000	10	40	
104	1000	10	40	
105	1000	10	40	
106	1000	10	40	
107	1000	10	40	
108	1000	10	40	
109	1000	10	40	
110	1000	10	40	
111	1000	10	40	
112	1000	10	40	
113	1000	10	40	
114	1000	10	40	
115	1000	10	40	
116	1000	10	40	
117	1000	10	40	
118	1000	10	40	
119	1000	10	40	
120	1000	10	40	
121	1000	10	40	
122	1000	10	40	
123	1000	10	40	
124	1000	10	40	
125	1000	10	40	
126	1000	10	40	
127	1000	10	40	
128	1000	10	40	
129	1000	10	40	
130	1000	10	40	
131	1000	10	40	
132	1000	10	40	
133	1000	10	40	
134	1000	10	40	
135	1000	10	40	
136	1000	10	40	
137	1000	10	40	
138	1000	10	40	
139	1000	10	40	
140	1000	10	40	
141	1000	10	40	
142	1000	10	40	
143	1000	10	40	
144	1000	10	40	
145	1000	10	40	
146	1000	10	40	
147	1000	10	40	
148	1000	10	40	
149	1000	10	40	
150	1000	10	40	
151	1000	10	40	
152	1000	10	40	
153	1000	10	40	
154	1000	10	40	
155	1000	10	40	
156	1000	10	40	
157	1000	10	40	
158	1000	10	40	
159	1000	10	40	
160	1000	10	40	
161	1000	10	40	
162	1000	10	40	
163	1000	10	40	
164	1000	10	40	
165	1000	10	40	
166	1000	10	40	
167	1000	10	40	
168	1000	10	40	
169	1000	10	40	
170	1000	10	40	
171	1000	10	40	
172	1000	10	40	
173	1000	10	40	
174	1000	10	40	
175	1000	10	40	
176	1000	10	40	
177	1000	10	40	
178	1000	10	40	
179	1000	10	40	
180	1000	10	40	
181	1000	10	40	
182	1000	10	40	
183	1000	10	40	
184	1000	10	40	
185	1000	10	40	
186	1000	10	40	
187	1000	10	40	
188	1000	10	40	
189	1000	10	40	
190	1000	10	40	
191	1000	10	40	
192	1000	10	40	
193	1000	10	40	
194	1000	10	40	
195	1000	10	40	
196	1000	10	40	
197	1000	10	40	
198	1000	10	40	
199	1000	10	40	
200	1000	10	40	

Luminaire data is obtained according to IES procedures under laboratory conditions. Field results may differ from computer model due to many factors, including ambient temperature, the voltage variations, lamp performance, installation, reflectances, and other site specific conditions.

**DRAWINGS FOR REVIEW ONLY  
DO NOT USE AS CONSTRUCTION DOCUMENTS**



Putterman, Scharck, & Associates, Inc.  
10000 W. 15th Ave.  
Suite 100  
Denver, CO 80202  
303.751.1000  
psa@psaassociates.com

XXX	XXX
Form and Plot	Figure Title
10/10/2021	RL



**Job Name:**  
FROSTWOOD ELEMENTARY

**Catalog Number:**  
EPH-LS-08-0640L-BLK-40-70-3S-  
C04-HV-AM-LY-A00-VHE-BP-ST  
Notes:

**Type:**  
**F3/F4/F5**

PSA21-145486

Project	Catalog #	Type
Prepared by	Notes	Date

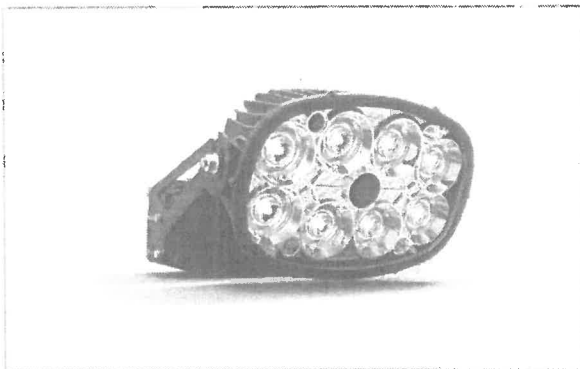

## Ephesus LUMASPORT 8

White LED Sports & Entertainment Luminaire

**Typical Applications**

Pro Arenas • University & Collegiate Arenas • University & Collegiate Stadiums • Multi-Event & Convention Centers • Gymnasiums & Field Houses

**Interactive Menu**

- Dimensional Details [page 1](#)
- Ordering Information [page 2](#)
- Dimensional and Mounting Details [page 3](#)
- Visor (VHE) Configuration [page 4](#)
- Performance Data [page 5](#)
- Optical Performance Data [page 6](#)
- Ordering Information for Accessories [page 8](#)
- Accessory Dimensions and Part Details [page 9](#)
- Example System Topology [page 12](#)

**Product Certification**



**Top Product Features**

- 55,000 or 90,000 lumen output options
- Glare and cutoff control via Hybrid Reflector and TIR Optical System
- Reduce install time with pre-aimable two-piece assembly
- Virtually eliminate maintenance with power redundancy
- Industry leading light source reliability with Chip-on-Board LEDs
- Greater than 92% lumen maintenance at 55,000 hours
- Wireless AirMesh, Wired DMX or sACN controls options to suit your needs

**Dimensional Details**

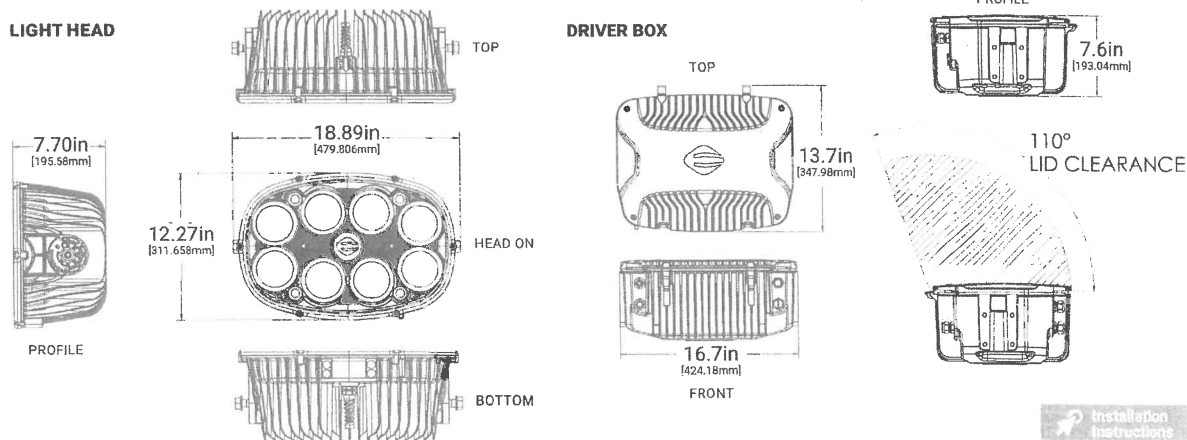



**Job Name:**  
FROSTWOOD ELEMENTARY

**Catalog Number:**  
SLX60-D21-100-G-2GSS4 W/  
(2)CXA5180  
Notes:

**Type:**  
**POLE**  
PSA21-145486

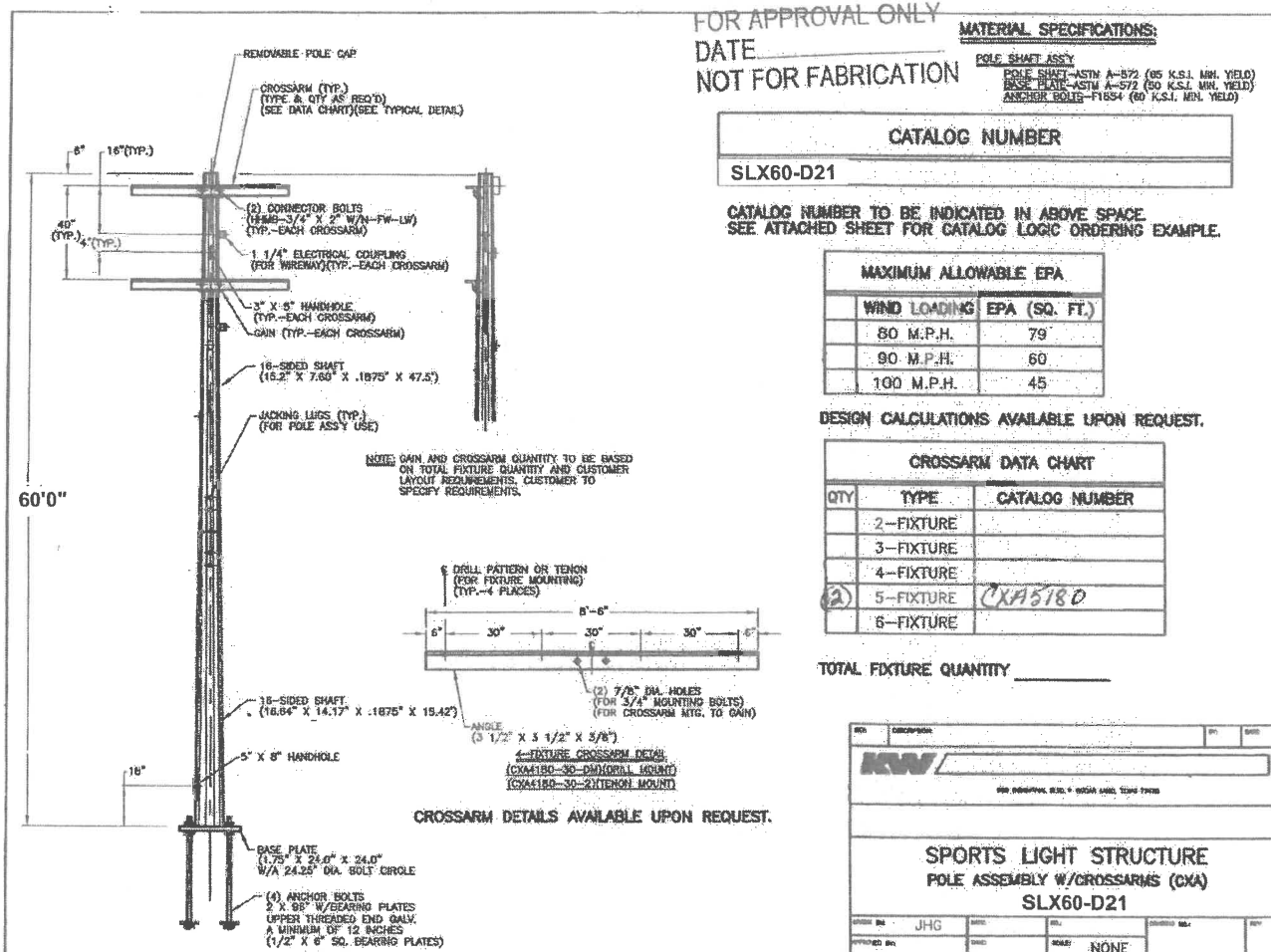

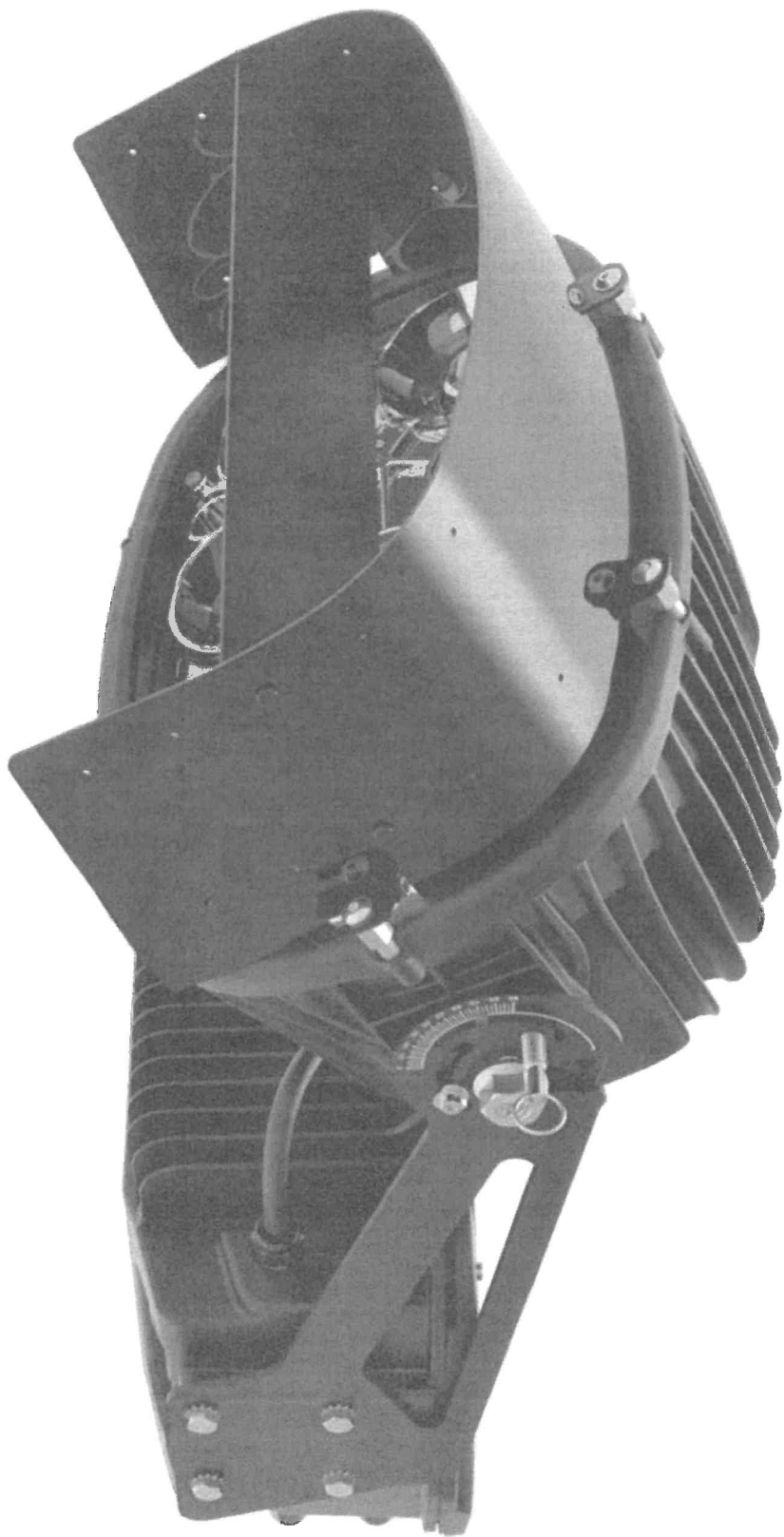



**ORDINANCE NO. 12-413**

**AN ORDINANCE OF THE CITY OF BUNKER HILL VILLAGE, TEXAS, AMENDING APPENDIX "A" OF THE CODE OF ORDINANCES OF THE CITY, SAME BEING THE COMPREHENSIVE ZONING ORDINANCE OF SAID CITY, BY GRANTING A SPECIFIC USE PERMIT TO THE SPRING BRANCH INDEPENDENT SCHOOL DISTRICT, AUTHORIZING CONSTRUCTION OF FROSTWOOD ELEMENTARY SCHOOL, 12214 MEMORIAL DRIVE; PROVIDING FOR REPEAL; PROVIDING A PENALTY OF AN AMOUNT NOT TO EXCEED \$2000 FOR EACH DAY OF VIOLATION OF ANY PROVISION HEREOF; AND PROVIDING FOR SEVERABILITY.**

WHEREAS, Section 8.02 of Appendix "A: of the Code of Ordinances of the City of Bunker Hill Village, Texas, said Appendix "A" being the comprehensive zoning ordinance of said City, permits the construction and use of educational facilities only pursuant to a specific use permit granted in accordance with Article VIII of said Appendix "A"; and

WHEREAS, The Spring Branch Independent School District has applied for a specific use permit for the construction and use of educational facilities on its premises located within said City, in accordance with the plan attached hereto as Exhibit "A" and made a part hereof; and

WHEREAS, the Planning & Zoning Commission of said City, after notice and hearings as required by law, has recommended that the City Council grant the specific use permit; and

WHEREAS, the City Council, following notice and hearing as required by law, concurs with the recommendation of the Planning & Zoning Commission that such specific use permit should be granted; now, therefore

**BE IT ORDAINED BY THE CITY COUNCIL OF THE CITY OF BUNKER HILL VILLAGE, TEXAS:**

**Section 1.** A specific use permit authorizing construction and use of an educational facility, to be located on the premises of the Spring Branch Independent School District, 12214 Memorial Drive, Bunker Hill Village, Texas, is hereby granted in accordance with the plans attached hereto as Exhibit "A" and in accordance with and

subject to the special terms and conditions set forth in Section 2 of this Ordinance. Said Exhibit "A" is made a part of this Ordinance for all purposes.

**Section 2.** The granting of the Specific Use Permit as set forth in Section 1 above is subject to the following additional terms and conditions:

- a. The sign lighting grid being a monochromatic, subdued color, such as amber or other color approved by the city engineer, and to be turned on only from dawn to dusk.

**Section 3.** Repeal. All ordinances or parts of ordinances inconsistent or in conflict herewith are, to the extent of such inconsistency or conflict, hereby repealed.

**Section 4.** Penalty. Any person who shall violate any provision of this Ordinance shall be deemed guilty of a misdemeanor and, upon conviction, shall be fined in an amount not to exceed \$2000. Each day of violation shall constitute a separate offense.

**Section 5.** Severability. In the event any section, paragraph, subdivision, clause, phrase, provision, sentence, or part of this Ordinance or the application of the same to any person or circumstance shall for any reason be adjudged invalid or held unconstitutional by a court of competent jurisdiction, it shall not affect, impair, or invalidate this Ordinance as a whole or any part or provision hereof other than the part declared to be invalid or unconstitutional; and the City Council of the City of Bunker Hill Village, Texas, declares that it would have passed each and every part of the same notwithstanding the omission of any such part thus declared to be invalid or unconstitutional, or whether there be one or more parts.

**PASSED, APPROVED, AND ADOPTED** this 17<sup>th</sup> day of April, 2012.

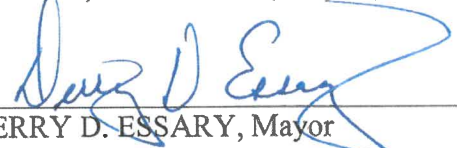
  
\_\_\_\_\_  
DERRY D. ESSARY, Mayor

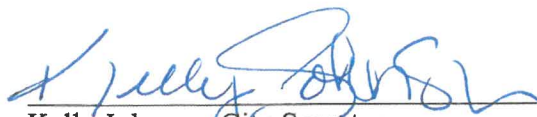
  
\_\_\_\_\_  
Kelly Johnson, City Secretary

# Frostwood Elementary School

## Spring Branch Independent School District

12214 Memorial Dr.  
Houston, TX 77024

### CONSTRUCTION DOCUMENTS

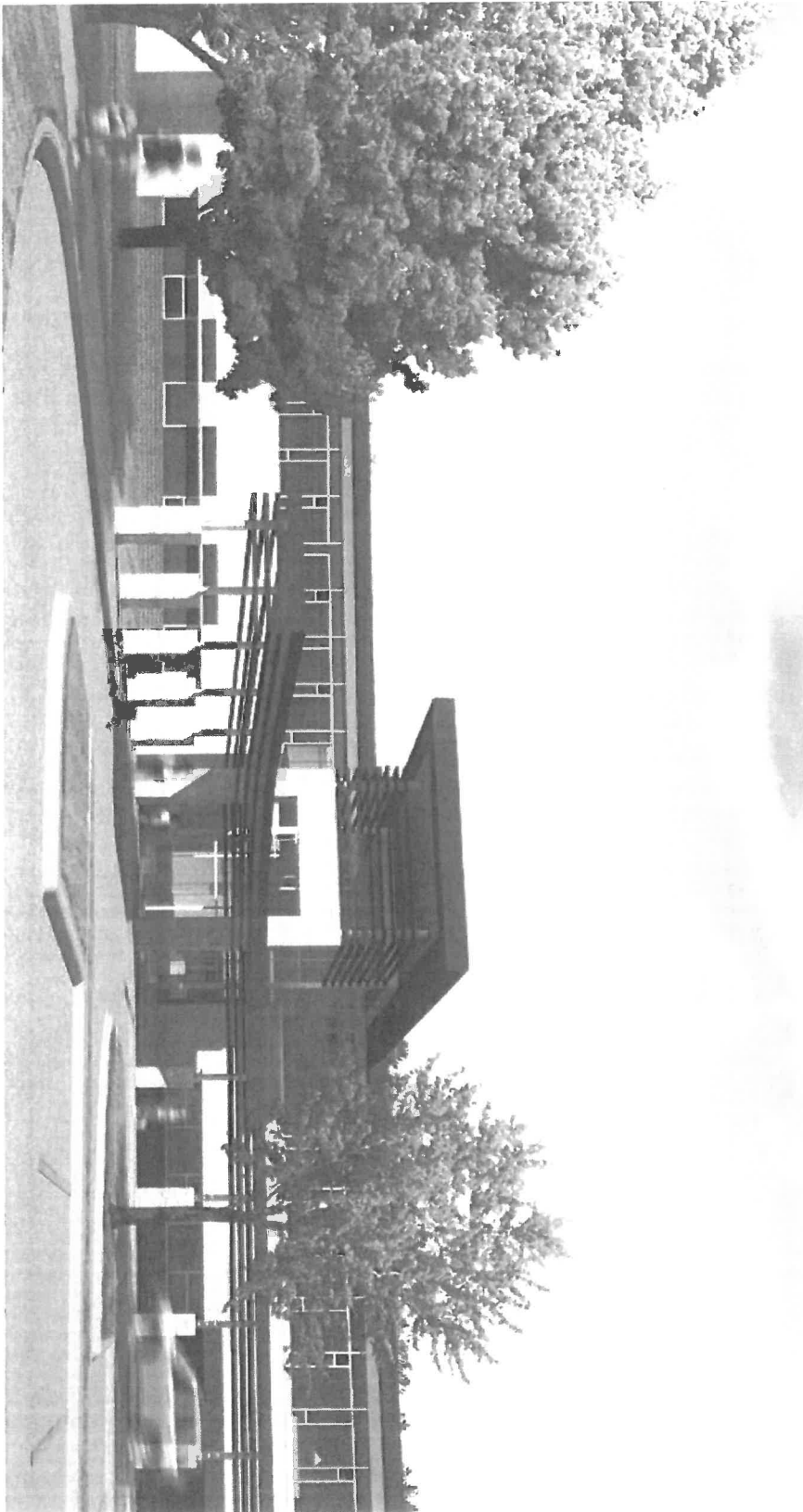

**ARCHITECT**  
Pfluger Associates Architects  
4918 Main St. Ste. 100  
Houston, TX 77002  
PH: 713.222.1141  
FAX: 713.222.1174  
www.pflugerarchitects.com

**CIVIL ENGINEER**  
Brooks & Sowers  
21020 Poyner Row Dr.  
Houston, TX 77049  
PH: 281.578.8995  
FAX: 281.578.8936  
www.brooks-sowers.com

**STRUCTURAL ENGINEER**  
CIG Engineers  
3300 - Iquest Dr. e. Suite 275  
Houston, TX 77042  
Phone: 713.764.3345  
Fa : 713.762.3712  
www.cigengineers.com

**MEE ENGINEER**  
DBR Engineers  
9500 Richmond A. e. Ste. 300  
Houston, TX 77042  
PH: 713.914.0888  
FAX: 713.914.0888  
www.dbrinc.com

**LANDSCAPE ARCHITECT**  
Ara um Robinson  
1802 Ashington A. area, Suite A  
Houston, TX 77067  
PH: 713.337.0250  
FAX: 832.261.7188  
www.ara-umrobinson.com

**FOOD SERVICE**  
Food Design Professionals  
28216 Oak Ridge Dr. e  
The Woodlands, TX 77380  
PH: 281.359.2223  
FAX: 281.359.2525  
www.fooddesignprofessionals.com



Spring Branch Independent School District  
955 Campbell St.  
Houston, TX 77024  
PH: 713.644.1511

1/8" = 1'-0"  
1/4" = 3'-0"  
1/2" = 6'-0"  
3/4" = 9'-0"  
1" = 12'-0"

A00  
COMB

Frostwood Elementary School  
Spring Branch Independent School District  
12214 Memorial Dr.  
Houston, TX 77024  
CONSTRUCTION DOCUMENTS

**pfluger**  
204 S. 17th Street, Suite 100, Houston, TX 77002  
www.pflugerarchitects.com

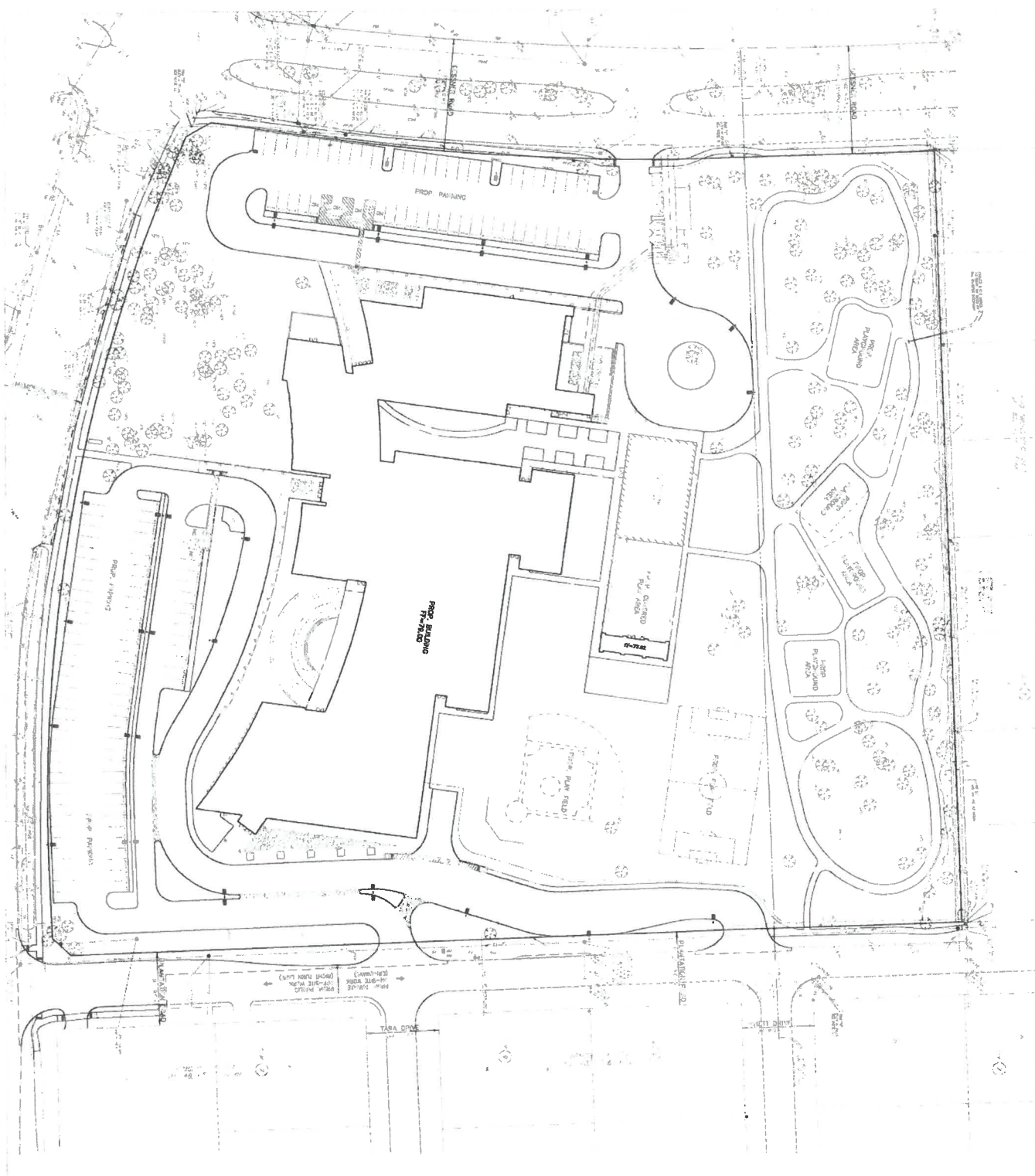

**C102**  
 CIVIL SITE PLAN

Spring Branch Independent School District  
 955 Campbell St.  
 Houston, TX 77024  
 PH: 713.644.1511

**Frostwood Elementary School**  
 Spring Branch Independent School District  
 12214 Memorial Dr.  
 Houston, TX 77024  
**CONSTRUCTION DOCUMENTS**

**pfluger**  
 8009 413 001114 | PH: 713.222.1174  
 4713 Main Street, Suite 100 | Houston, Texas 77002  
 pfluger@pfluger.com



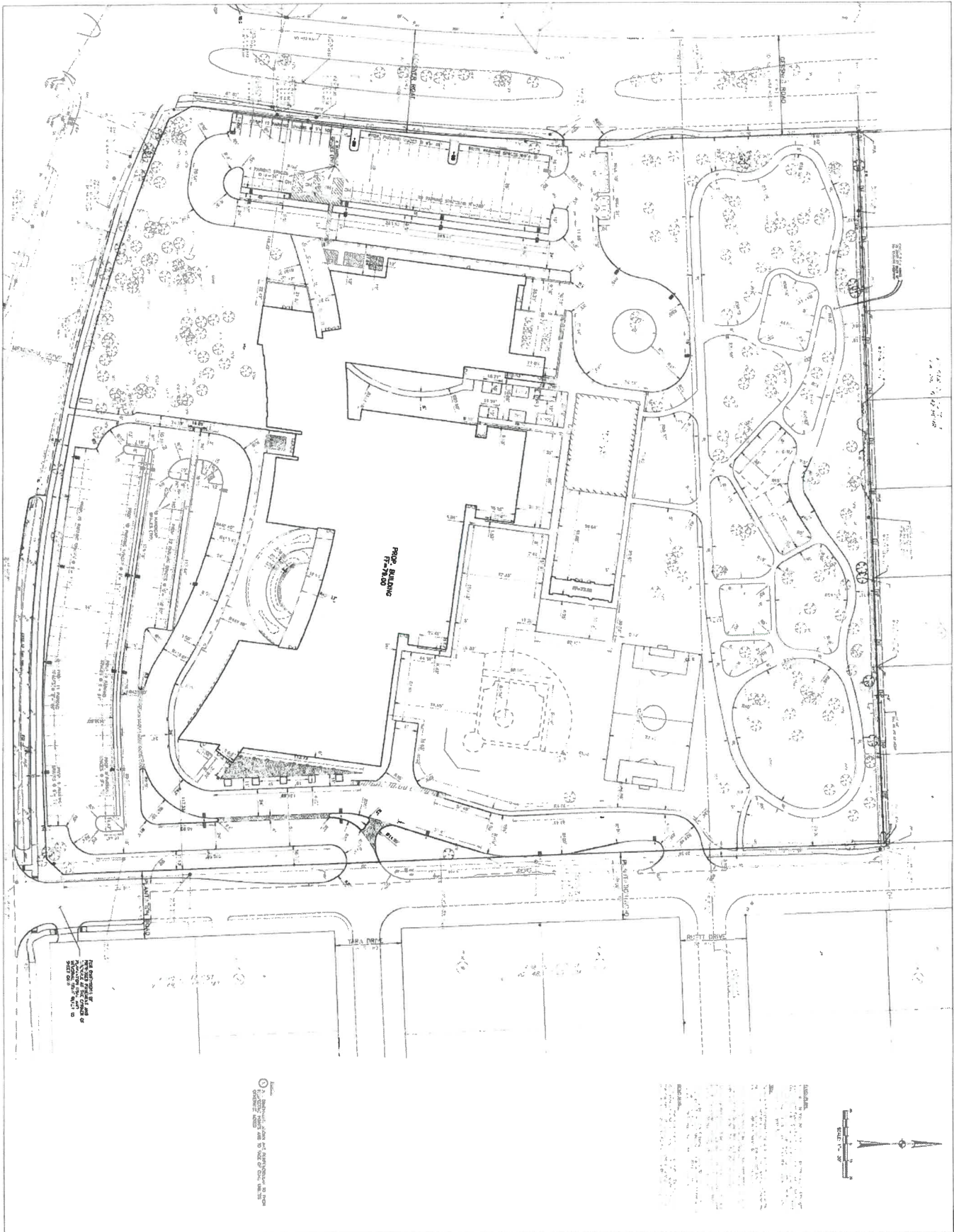

**C104**  
DIMENSIONAL  
LAYOUT

Spring Branch Independent  
School District  
855 Campbell St.  
Houston, TX 77024  
PH: 713.644.1511

**Frostwood Elementary School**  
Spring Branch Independent School District  
12214 Memorial Dr.  
Houston, TX 77024  
**CONSTRUCTION DOCUMENTS**

**pfluger**  
Office: 713.713.1161 | Fax: 713.713.4174  
1916 Loop West, Suite 100, Houston, Texas 77058  
pflugerarchitect.com

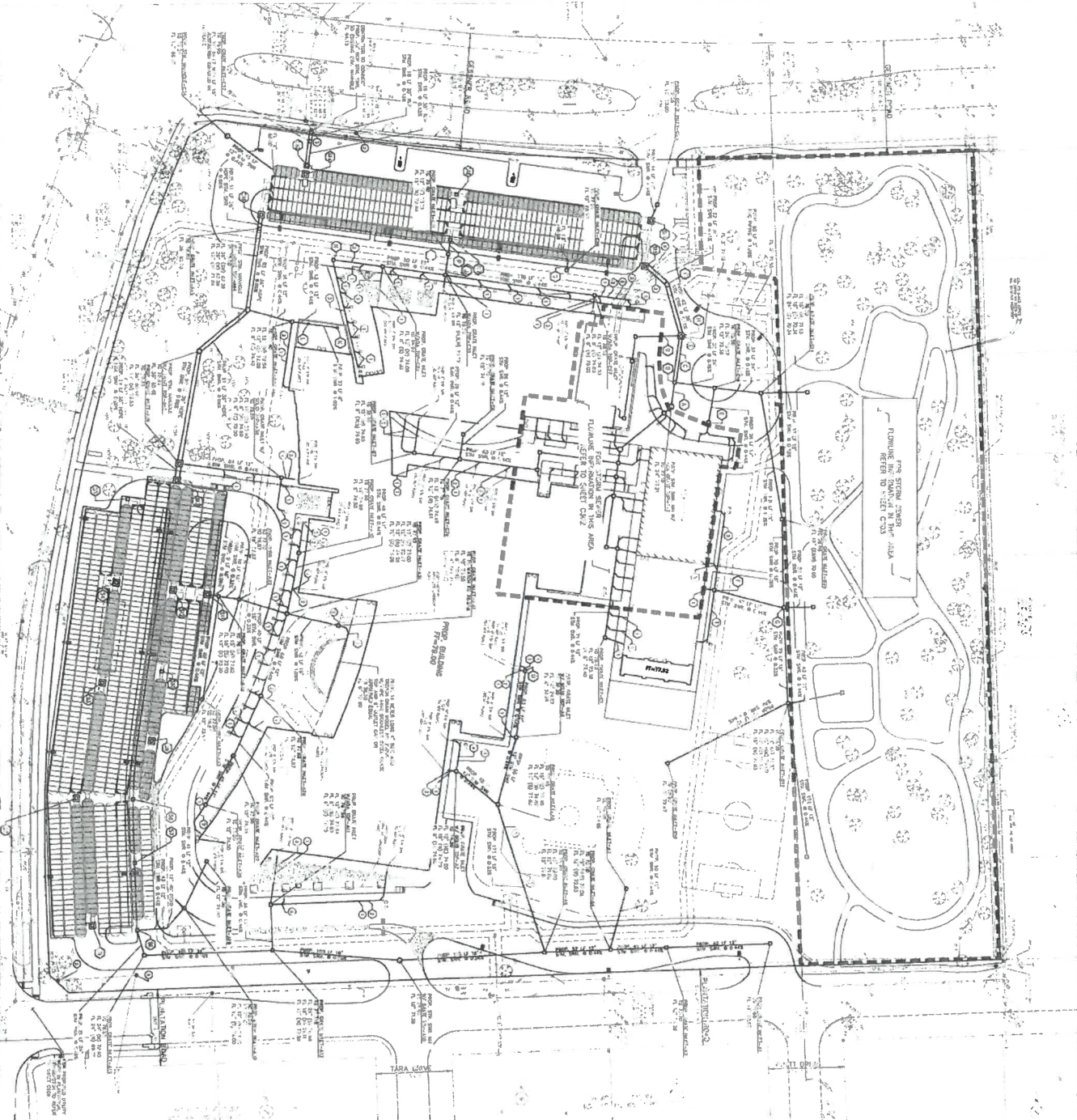

- LEGEND**
- 1. REMOVE EXISTING CONCRETE
  - 2. REMOVE EXISTING CURB
  - 3. REMOVE EXISTING ASPHALT
  - 4. REMOVE EXISTING GRAVEL
  - 5. REMOVE EXISTING SAND
  - 6. REMOVE EXISTING GRAVEL
  - 7. REMOVE EXISTING SAND
  - 8. REMOVE EXISTING GRAVEL
  - 9. REMOVE EXISTING SAND
  - 10. REMOVE EXISTING GRAVEL
  - 11. REMOVE EXISTING SAND
  - 12. REMOVE EXISTING GRAVEL
  - 13. REMOVE EXISTING SAND
  - 14. REMOVE EXISTING GRAVEL
  - 15. REMOVE EXISTING SAND
  - 16. REMOVE EXISTING GRAVEL
  - 17. REMOVE EXISTING SAND
  - 18. REMOVE EXISTING GRAVEL
  - 19. REMOVE EXISTING SAND
  - 20. REMOVE EXISTING GRAVEL
  - 21. REMOVE EXISTING SAND
  - 22. REMOVE EXISTING GRAVEL
  - 23. REMOVE EXISTING SAND
  - 24. REMOVE EXISTING GRAVEL
  - 25. REMOVE EXISTING SAND
  - 26. REMOVE EXISTING GRAVEL
  - 27. REMOVE EXISTING SAND
  - 28. REMOVE EXISTING GRAVEL
  - 29. REMOVE EXISTING SAND
  - 30. REMOVE EXISTING GRAVEL
  - 31. REMOVE EXISTING SAND
  - 32. REMOVE EXISTING GRAVEL
  - 33. REMOVE EXISTING SAND
  - 34. REMOVE EXISTING GRAVEL
  - 35. REMOVE EXISTING SAND
  - 36. REMOVE EXISTING GRAVEL
  - 37. REMOVE EXISTING SAND
  - 38. REMOVE EXISTING GRAVEL
  - 39. REMOVE EXISTING SAND
  - 40. REMOVE EXISTING GRAVEL
  - 41. REMOVE EXISTING SAND
  - 42. REMOVE EXISTING GRAVEL
  - 43. REMOVE EXISTING SAND
  - 44. REMOVE EXISTING GRAVEL
  - 45. REMOVE EXISTING SAND
  - 46. REMOVE EXISTING GRAVEL
  - 47. REMOVE EXISTING SAND
  - 48. REMOVE EXISTING GRAVEL
  - 49. REMOVE EXISTING SAND
  - 50. REMOVE EXISTING GRAVEL
  - 51. REMOVE EXISTING SAND
  - 52. REMOVE EXISTING GRAVEL
  - 53. REMOVE EXISTING SAND
  - 54. REMOVE EXISTING GRAVEL
  - 55. REMOVE EXISTING SAND
  - 56. REMOVE EXISTING GRAVEL
  - 57. REMOVE EXISTING SAND
  - 58. REMOVE EXISTING GRAVEL
  - 59. REMOVE EXISTING SAND
  - 60. REMOVE EXISTING GRAVEL
  - 61. REMOVE EXISTING SAND
  - 62. REMOVE EXISTING GRAVEL
  - 63. REMOVE EXISTING SAND
  - 64. REMOVE EXISTING GRAVEL
  - 65. REMOVE EXISTING SAND
  - 66. REMOVE EXISTING GRAVEL
  - 67. REMOVE EXISTING SAND
  - 68. REMOVE EXISTING GRAVEL
  - 69. REMOVE EXISTING SAND
  - 70. REMOVE EXISTING GRAVEL
  - 71. REMOVE EXISTING SAND
  - 72. REMOVE EXISTING GRAVEL
  - 73. REMOVE EXISTING SAND
  - 74. REMOVE EXISTING GRAVEL
  - 75. REMOVE EXISTING SAND
  - 76. REMOVE EXISTING GRAVEL
  - 77. REMOVE EXISTING SAND
  - 78. REMOVE EXISTING GRAVEL
  - 79. REMOVE EXISTING SAND
  - 80. REMOVE EXISTING GRAVEL
  - 81. REMOVE EXISTING SAND
  - 82. REMOVE EXISTING GRAVEL
  - 83. REMOVE EXISTING SAND
  - 84. REMOVE EXISTING GRAVEL
  - 85. REMOVE EXISTING SAND
  - 86. REMOVE EXISTING GRAVEL
  - 87. REMOVE EXISTING SAND
  - 88. REMOVE EXISTING GRAVEL
  - 89. REMOVE EXISTING SAND
  - 90. REMOVE EXISTING GRAVEL
  - 91. REMOVE EXISTING SAND
  - 92. REMOVE EXISTING GRAVEL
  - 93. REMOVE EXISTING SAND
  - 94. REMOVE EXISTING GRAVEL
  - 95. REMOVE EXISTING SAND
  - 96. REMOVE EXISTING GRAVEL
  - 97. REMOVE EXISTING SAND
  - 98. REMOVE EXISTING GRAVEL
  - 99. REMOVE EXISTING SAND
  - 100. REMOVE EXISTING GRAVEL

C301  
STORAGE ER  
SHEET 1 OF 3

Spring Branch Independent School District  
955 Campbell St.  
Houston, TX 77024  
PH: 713.844.1511

Frostwood Elementary School  
Spring Branch Independent School District  
12214 Memorial Dr.  
Houston, TX 77061  
**CONSTRUCTION DOCUMENTS**

**pfluger**  
Office: 713.262.1141 • Fax: 713.252.1174  
4718 West Street, Suite 100, Houston, Texas 77056  
pfluger@pflugs.com



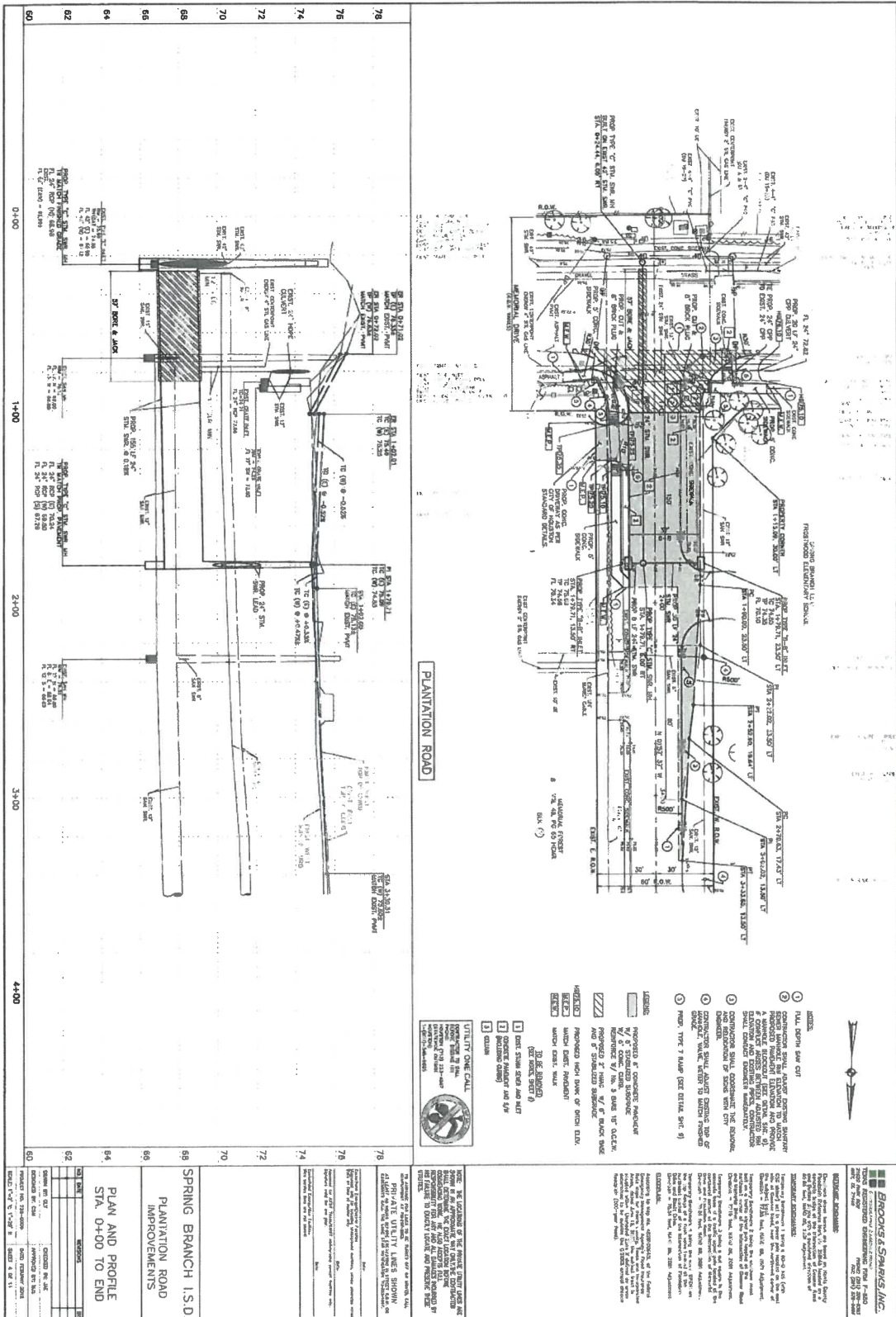

C606  
 PUBLIC  
 PLAN & PROFILE

Spring Branch Independent School District  
 955 Campbell St.  
 Houston, TX 77024  
 PH: 713.644.1511

Frostwood Elementary School  
 Spring Branch Independent School District  
 12214 Memorial Dr.  
 Houston, TX 77024

CONSTRUCTION DOCUMENTS

pfluger  
 4811 S. GULF SHORE DR., SUITE 100, HOUSTON, TX 77057  
 713.661.1111

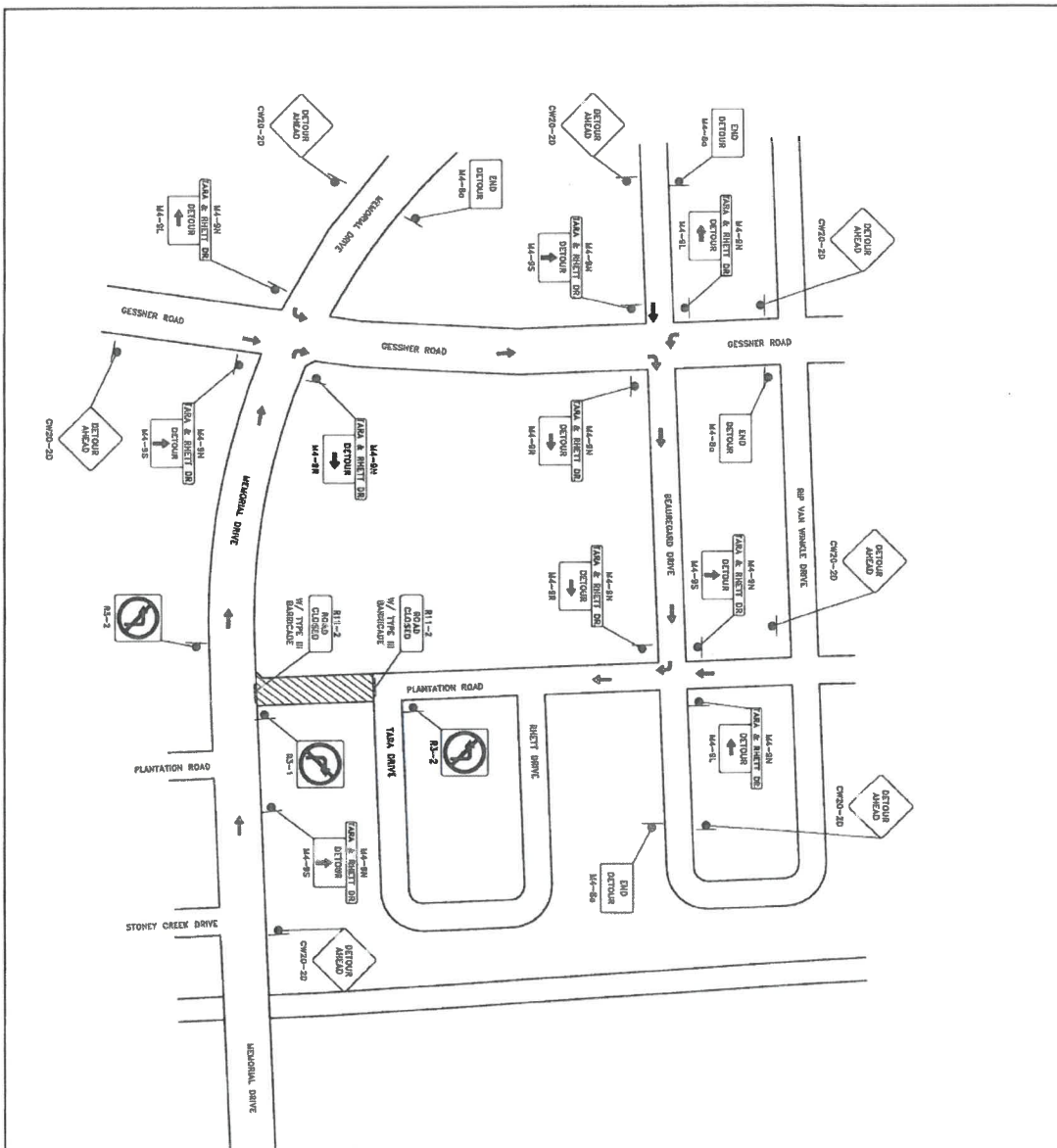

- TRAFFIC NOTES**
1. CONSTRUCTION SHALL BE COMPLETED BY THE DATE INDICATED ON THE SIGNAGE. ALL SIGNAGE SHALL BE MAINTAINED THROUGHOUT THE CONSTRUCTION PERIOD.
  2. CONSTRUCTION SHALL MAINTAIN ADEQUATE CLEARANCE FOR TRAFFIC TO PASS SAFELY THROUGH THE CONSTRUCTION AREA.
  3. CONSTRUCTION SHALL MAINTAIN ADEQUATE CLEARANCE FOR TRAFFIC TO PASS SAFELY THROUGH THE CONSTRUCTION AREA.
  4. CONSTRUCTION SHALL MAINTAIN ADEQUATE CLEARANCE FOR TRAFFIC TO PASS SAFELY THROUGH THE CONSTRUCTION AREA.
  5. CONSTRUCTION SHALL MAINTAIN ADEQUATE CLEARANCE FOR TRAFFIC TO PASS SAFELY THROUGH THE CONSTRUCTION AREA.
  6. CONSTRUCTION SHALL MAINTAIN ADEQUATE CLEARANCE FOR TRAFFIC TO PASS SAFELY THROUGH THE CONSTRUCTION AREA.
  7. CONSTRUCTION SHALL MAINTAIN ADEQUATE CLEARANCE FOR TRAFFIC TO PASS SAFELY THROUGH THE CONSTRUCTION AREA.
  8. CONSTRUCTION SHALL MAINTAIN ADEQUATE CLEARANCE FOR TRAFFIC TO PASS SAFELY THROUGH THE CONSTRUCTION AREA.
  9. CONSTRUCTION SHALL MAINTAIN ADEQUATE CLEARANCE FOR TRAFFIC TO PASS SAFELY THROUGH THE CONSTRUCTION AREA.
  10. CONSTRUCTION SHALL MAINTAIN ADEQUATE CLEARANCE FOR TRAFFIC TO PASS SAFELY THROUGH THE CONSTRUCTION AREA.

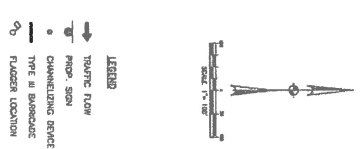

<p><b>BRIDGES &amp; SPANNING, INC.</b>                  11000 Katy Road, Suite 100, Houston, TX 77024                  281.468.1111</p>	
<p><b>PROJECT INFORMATION</b></p> <p>PROJECT NO: 735-09                  PROJECT NAME: SPRING BRANCH I.S.D. TARA DRIVE AND RHETT DRIVE DETOUR PLAN                  DATE: 03/07/12</p>	
<p><b>DESIGNER</b>                  BRIDGES &amp; SPANNING, INC.</p>	
<p><b>CHECKED</b>                  BRIDGES &amp; SPANNING, INC.</p>	
<p><b>DATE</b>                  03/07/12</p>	

<p>Spring Branch Independent School District                  935 Campbell St                  Houston, TX 77024                  PH: 713.644.1511</p>	<p><b>Frostwood Elementary School</b>                  Spring Branch Independent School District                  12514 Memorial Dr.                  Houston, TX 77024</p> <p><b>CONSTRUCTION DOCUMENTS</b></p>	<p><b>pfluger</b>                  801.221.5141                  801.221.5142                  801.221.5143                  801.221.5144                  801.221.5145                  801.221.5146                  801.221.5147                  801.221.5148                  801.221.5149                  801.221.5150                  801.221.5151                  801.221.5152                  801.221.5153                  801.221.5154                  801.221.5155                  801.221.5156                  801.221.5157                  801.221.5158                  801.221.5159                  801.221.5160                  801.221.5161                  801.221.5162                  801.221.5163                  801.221.5164                  801.221.5165                  801.221.5166                  801.221.5167                  801.221.5168                  801.221.5169                  801.221.5170</p>
--	--	---

C608  
 PUBLIC  
 TARA DRIVE  
 AND RHETT DRIVE  
 DETOUR PLAN



17 Section A-D

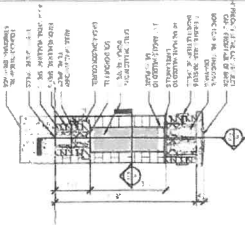

16 MARQUEE

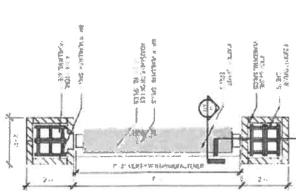

13 Marquee Floor Plan

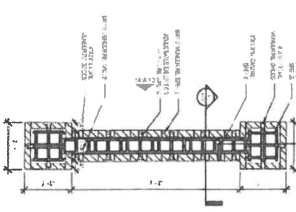

9 ENCLOSURE DETAIL

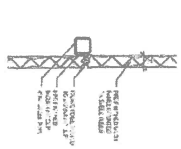

5 Reception Bn Plan

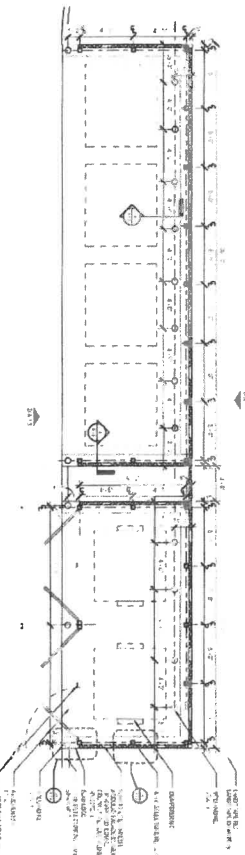

18 Section 3-3

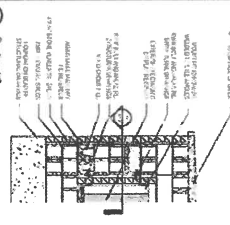

14 Enclosure 5-8

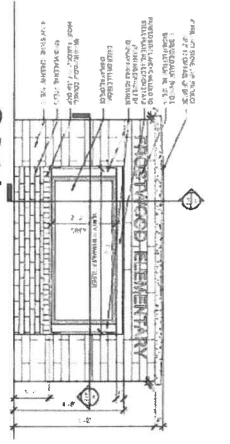

10 WARD GATE DETAIL

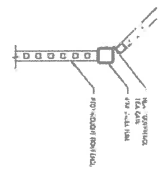

6 MOTORIZED ROLLING GATE

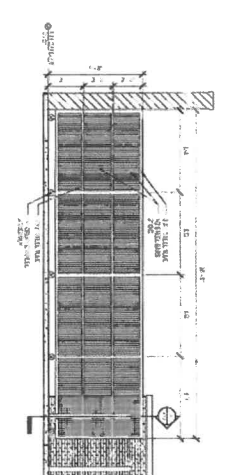

2 Dumpster Enclosure Elevation

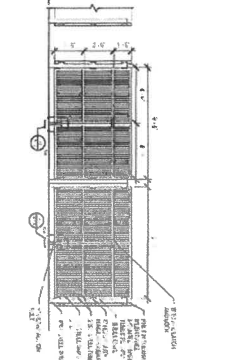

15 Enhanced Screen Wall Plan

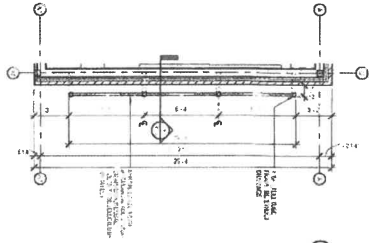

11 DUMPSTER ENCLOSURE GATE DETAIL

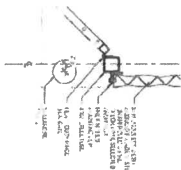

7 Dumpster Enclosure Elevation

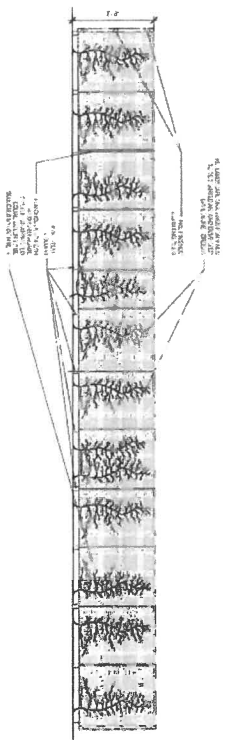

12 Retain Action Rail Detail

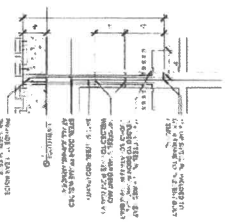

8 ROLLING GATE SECTION

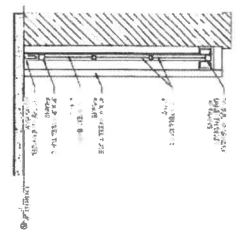

4 Dumpster Enclosure Section

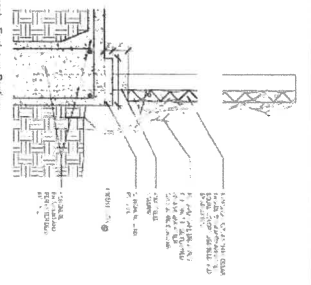

 Spring Branch Independent School District  
 895 Campbell St.  
 Houston, TX 77024  
 PH: 713.644.1511

**Frostwood Elementary School**  
 Spring Branch Independent School District  
 12214 Memorial Dr  
 Houston, TX 77064  
**CONSTRUCTION DOCUMENTS**

**pfluger**  
 1100 West Loop West, Suite 1000  
 Houston, Texas 77027  
 Phone: 713.865.1100  
 Fax: 713.865.1101  
 www.pfluger.com

A1.3  
 Sheet Details